

MSM7717-01/02/03**Single Rail CODEC****GENERAL DESCRIPTION**

The MSM7717 is a single-channel CODEC CMOS IC for voice signals ranging from 300 to 3400 Hz with filters for A/D and D/A conversion.

Designed especially for a single-power supply and low-power applications, the device is optimized for ISDN terminals and telephone terminals in digital wireless systems.

The device uses the same transmission clocks as those used in the MSM7508B and MSM7509B. The analog output, which can drive a 1.2 k Ω load, can directly drive a handset receiver differentially.

FEATURES

- Single power supply: 2.7 V to 3.8 V
- Low power consumption
 - Operating mode: 20 mW Typ. $V_{DD} = 3\text{ V}$
 - Power-down mode: 0.03 mW Typ. $V_{DD} = 3\text{ V}$
- Conforms to ITU-T Companding law
 - MSM7717-01: μ /A-law pin selectable
 - MSM7717-02: μ -law
 - MSM7717-03: A-law
- Built-in PLL eliminates a master clock
- Serial data rate: 64/128/256/512/1024 kHz
96/192/384/768/1536/1544/2048/200 kHz
- Adjustable transmit gain
- Adjustable receive gain
- Built-in reference voltage supply
- Package options:
 - 24-pin plastic SOP (SOP24-P-430-1.27-K) (Product name: MSM7717-01GS-K)
(Product name: MSM7717-02GS-K)
(Product name: MSM7717-03GS-K)
 - 20-pin plastic SSOP (SSOP20-P-250-0.95-K) (Product name: MSM7717-01MS-K)
(Product name: MSM7717-02MS-K)
(Product name: MSM7717-03MS-K)



Schareggstrasse 3, CH-5506 Mägenwil
Tel. +41 62 896 00 48, Fax. +41 62 896 25 80
info@admatec.ch, www.admatec.ch

BLOCK DIAGRAM

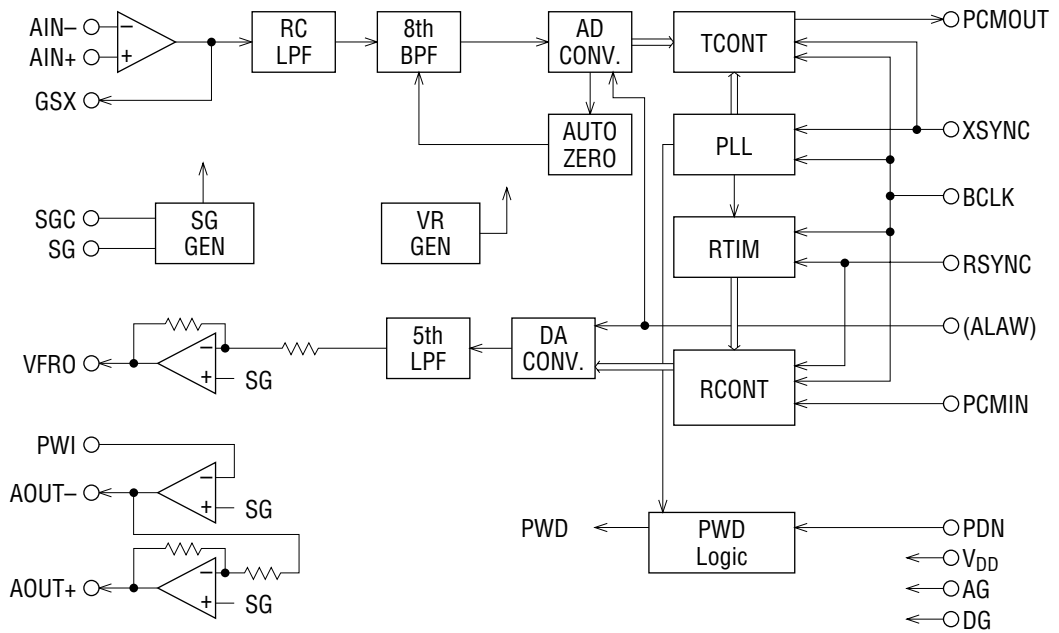

PIN CONFIGURATION (TOP VIEW)

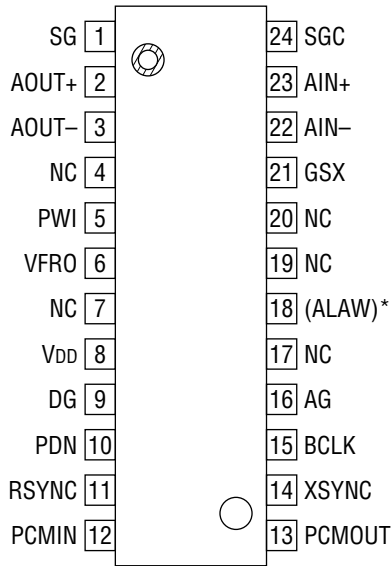

NC : No connect pin
24-Pin Plastic SOP

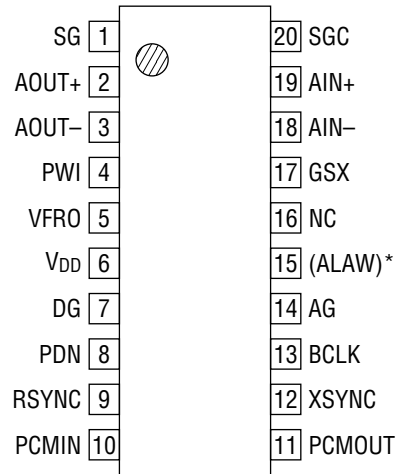

NC : No connect pin
20-Pin Plastic SSOP

* The ALAW pin is only supported by the MSM7717-01GS-K/MSM7717-01MS-K.

PIN AND FUNCTIONAL DESCRIPTIONS

AIN+, AIN-, GSX

Transmit analog input and transmit level adjustment.

AIN+ is a non-inverting input to the op-amp; AIN- is an inverting input to the op-amp; GSX is connected to the output of the op-amp.

The level adjustment should be performed in any method shown below. When not using AIN- and AIN+, connect AIN- to GSX and AIN+ to SG. During power-saving and power-down modes, the GSX output is at AG voltage.

1) Inverting input type

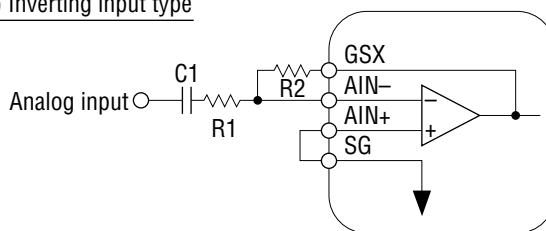

$$R1 : \text{variable}$$

$$R2 > 20 \text{ k}\Omega$$

$$C1 > 1/(2 \times 3.14 \times 30 \times R1) \text{ (F)}$$

$$\text{Gain} = R2/R1 < 10$$

2) Noninverting input type

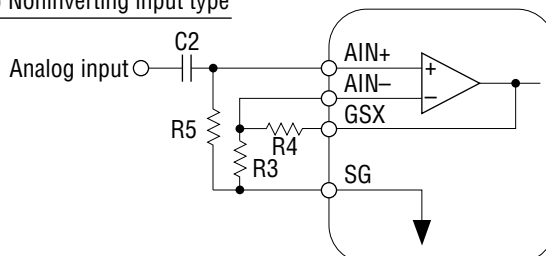

$$R3 > 20 \text{ k}\Omega$$

$$R4 > 20 \text{ k}\Omega$$

$$R5 > 50 \text{ k}\Omega$$

$$C2 > 1/(2 \times 3.14 \times 30 \times R5) \text{ (F)}$$

$$\text{Gain} = 1 + R4 / R3 \leq 10$$

AG

Analog signal ground.

VFRO

Receive filter output.

The output signal has an amplitude of 2.0 V_{PP} above and below the signal ground voltage (SG) when the digital signal of +3 dBm₀ is input to PCMIN and can drive a load of 20 kΩ or more. For driving a load of less than 20 kΩ, connect a resistor of 20 kΩ or more between the pins VFRO and PWI.

During power-saving mode this output is in a high impedance state, and during power-down mode, the VFRO output is at an SG level.

When adjusting the receive signal on the basis of frequency characteristics, refer to the Frequency Characteristics Adjustment Circuit.

PWI, AOUT+, AOUT-

PWI is connected to the inverting input of the receive driver. The receive driver output is connected to the AOUT- pin. Therefore, the receive level can be adjusted with the pins VFRO, PWI, and AOUT-. When the PWI pin is not used, the PWI pin to the AOUT- pin, and leave the pins AOUT- and AOUT+ open. The output of AOUT+ is inverted with respect to the output of AOUT-. Since these outputs provide differential drive of an impedance of 1.2 kΩ, these outputs can directly be connected to a receiver of handset using a piezoelectric earphone. Refer to the application example. Since the driver amplifiers are being activated during the power-saving mode, the amplifiers can output other external signals from AOUT+ and AOUT- pins. AOUT+ and AOUT- outputs are in a high impedance state during the power-down mode.

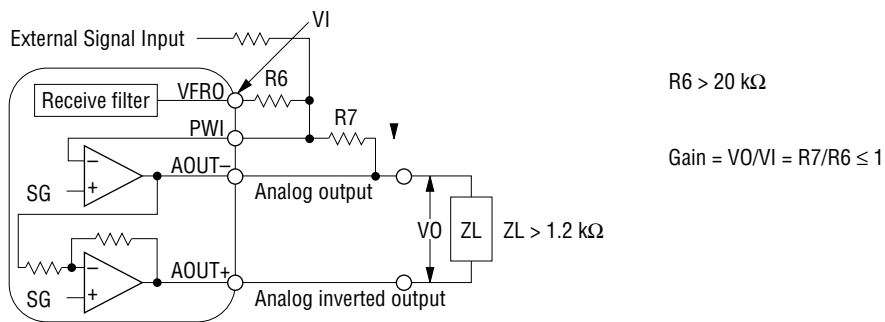

V_{DD}

Power supply for 2.7 V to 3.8 V. (Typically 3.0 V)

PCMIN

PCM data input.

A serial PCM data input to this pin is converted to an analog signal in synchronization with the RSYNC signal and BCLK signal.

The data rate of PCM is equal to the frequency of the BCLK signal.

PCM signal is shifted in at a falling edge of the BCLK signal and latched into the internal register when shifted by eight bits.

The start of the PCM data (MSD) is identified at the rising edge of RSYNC.

BCLK

Shift clock signal input for the PCMIN and PCMOUT signal.

The frequency, equal to the data rate, is 64, 96, 128, 192, 256, 384, 512, 768, 1024, 1536, 1544, or 2048 kHz. Setting this signal to logic "1" or "0" drives both transmit and receive circuits to the power saving state.

The power-saving state means that the reference voltage generator (VRGEN), PLL, and receive driver amplifiers are in the operating mode and the other circuits are in the non-operating mode.

RSYNC

Receive synchronizing signal input.

Eight required bits are selected from serial PCM signals on the PCMIN pin by the receive synchronizing signal.

Signals in the receive section are synchronized by this synchronizing signal. This signal must be synchronized in phase with the BCLK. The frequency should be $8\text{ kHz} \pm 50\text{ ppm}$ to guarantee the AC characteristics which are mainly the frequency characteristics of the receive section.

However, if the frequency characteristic of an applied system is not specified exactly, this device can operate in the range of $8\text{ kHz} \pm 2\text{ kHz}$, but the electrical characteristics in this specification are not guaranteed.

XSYNC

Transmit synchronizing signal input.

The PCM output signal from the PCMOUT pin is output in synchronization with this signal. This synchronizing signal triggers the PLL and synchronizes all timing signals of the transmit section. This synchronizing signal must be synchronized in phase with BCLK.

The frequency should be $8\text{ kHz} \pm 50\text{ ppm}$ to guarantee the AC characteristics which are mainly the frequency characteristics of the transmit section.

However, if the frequency characteristic of an applied system is not specified exactly, this device operates in the range of $8\text{ kHz} \pm 2\text{ kHz}$, but the electrical characteristics in this specification are not guaranteed.

Setting this signal to logic "1" or "0" drives both transmit and receive circuits to the power saving state.

DG

Ground for the digital signal circuits.

This ground is separate from the analog signal ground AG. The DG pin must be connected to the AG pin on the printed circuit board to make a common analog ground AG.

PDN

Power down control signal.

A logic "0" level drives both transmit and receive circuits to a power down state.

PCMOUT

PCM signal output.

Synchronizing with the rising edge of the BCLK signal, the PCM output signal is output from MSD in a sequential order.

MSD may be output at the rising edge of the XSYNC signal, based on the timing between BCLK and XSYNC.

This pin is in a high impedance state except during 8-bit PCM output. It is also in a high impedance state during power saving or power down mode.

A pull-up resistor must be connected to this pin because its output is configured as an open drain. This device is compatible with the ITU-T recommendation on coding law and output coding format.

The MSM7717-03 (A-law) outputs the character signal, inverting the even bits.

Input/Output Level	PCMIN/PCMOUT															
	MSM7717-02 (μ -law)				MSM7717-03 (A-law)											
+Full scale	MSD				MSD											
	1	0	0	0	0	0	0	0	1	0	1	0	1	0	1	0
+0	1	1	1	1	1	1	1	1	1	1	0	1	0	1	0	1
-0	0	1	1	1	1	1	1	1	0	1	0	1	0	1	0	1
-Full scale	0	0	0	0	0	0	0	0	0	0	1	0	1	0	1	0

SG

Signal ground voltage output.

The output voltage is 1/2 of the power supply voltage.

The output drive current capability is $\pm 200 \mu\text{A}$.

This pin provides the SG level for CODEC peripherals.

This output voltage level is undefined during power-saving or power-down mode.

SGC

Used to generate the signal ground voltage level by connecting a bypass capacitor.

Connect a 0.1 μF capacitor with excellent high frequency characteristics between the AG pin and the SGC pin.

ALAW

Control signal input of the companding law selection.

Only the MSM7717-01GS-K/7717-01MS-K has this pin. The CODEC will operate in the μ -law when this pin is at a logic "0" level and the CODEC will have this pin operate in the A-law when this pin is at a logic "1" level. The CODEC operates in the μ -law if the pin is left open, since the pin is internally pulled down.

ABSOLUTE MAXIMUM RATINGS

Parameter	Symbol	Condition	Rating	Unit
Power Supply Voltage	V_{DD}	—	-0.3 to +7	V
Analog Input Voltage	V_{AIN}	—	-0.3 to $V_{DD} + 0.3$	V
Digital Input Voltage	V_{DIN}	—	-0.3 to $V_{DD} + 0.3$	V
Storage Temperature	T_{STG}	—	-55 to +150	°C

RECOMMENDED OPERATING CONDITIONS

Parameter	Symbol	Condition	Min.	Typ.	Max.	Unit
Power Supply Voltage	V_{DD}	Voltage must be fixed	2.7	3.0	3.8	V
Operating Temperature	T_a	—	-30	+25	+85	°C
Analog Input Voltage	V_{AIN}	Connect AIN- and GSX	—	—	1.4	V_{PP}
High Level Input Voltage	V_{IH}	XSYNC, RSYNC, BCLK,	$0.45 \times V_{DD}$	—	V_{DD}	V
Low Level Input Voltage	V_{IL}	PCMIN, PDN, ALAW	0	—	$0.16 \times V_{DD}$	V
Clock Frequency	F_C	BCLK	64, 128, 256, 512, 1024, 2048, 96, 192, 384, 768, 1536, 1544, 200			kHz
Sync Pulse Frequency	F_S	XSYNC, RSYNC	6.0	8.0	10	kHz
Clock Duty Ratio	D_C	BCLK	40	50	60	%
Digital Input Rise Time	t_{ir}	XSYNC, RSYNC, BCLK,	—	—	50	ns
Digital Input Fall Time	t_{if}	PCMIN, PDN, ALAW	—	—	50	ns
Transmit Sync Pulse Setting Time	t_{XS}	BCLK→XSYNC, See Fig. 1	100	—	—	ns
	t_{SX}	XSYNC→BCLK, See Fig. 1	100	—	—	ns
Receive Sync Pulse Setting Time	t_{RS}	BCLK→RSYNC, See Fig. 1	100	—	—	ns
	t_{SR}	RSYNC→BCLK, See Fig. 1	100	—	—	ns
High Level Sync Pulse Width	t_{WSH}	XSYNC, RSYNC, See Fig. 1	1 BCLK	—	—	μs
Low Level Sync Pulse Width	t_{WSL}	XSYNC, RSYNC, See Fig. 1	1 BCLK	—	—	μs
PCMIN Setup Time	t_{DS}	See Timing Diagram	100	—	—	ns
PCMIN Hold Time	t_{DH}	See Timing Diagram	100	—	—	ns
Digital Output Load	R_{DL}	Pull-up resistor	0.5	—	—	kΩ
	C_{DL}	—	—	—	100	pF
Analog Input Allowable DC Offset	V_{off}	Transmit gain stage, Gain = 1	-100	—	+100	mV
		Transmit gain stage, Gain = 10	-10	—	+10	mV
Allowable Jitter Width	—	XSYNC, RSYNC, BCLK	—	—	1000	ns

ELECTRICAL CHARACTERISTICS

DC and Digital Interface Characteristics

 ($V_{DD} = 2.7\text{ V to }3.8\text{ V}$, $T_a = -30^\circ\text{C to }+85^\circ\text{C}$)

Parameter	Symbol	Condition	Min.	Typ.	Max.	Unit	
Power Supply Current	I_{DD1}	Operating mode	$V_{DD} = 3.8\text{ V}$	—	10	14	mA
		No signal	$V_{DD} = 3.0\text{ V}$	—	6.5	10.0	
	I_{DD2}	Power-saving mode, PDN = 1, BCLK or XSYNC → OFF		—	2.0	8.0	mA
	I_{DD3}	Power-down mode, PDN = 0, BCLK OFF		—	0.005	0.05	mA
High Level Input Voltage	V_{IH}	XSYNC, RSYNC, BCLK, PCMIN, PDN, ALAW	$0.45 \times V_{DD}$	—	V_{DD}	V	
Low Level Input Voltage	V_{IL}	XSYNC, RSYNC, BCLK, PCMIN, PDN, ALAW	0.0	—	$0.16 \times V_{DD}$	V	
High Level Input Leakage Current	I_{IH}	—	—	—	2.0	μA	
Low Level Input Leakage Current	I_{IL}	—	—	—	0.5	μA	
Digital Output Low Voltage	V_{OL}	Pull-up resistor > 500 Ω	0.0	0.2	0.4	V	
Digital Output Leakage Current	I_O	—	—	—	10	μA	
Input Capacitance	C_{IN}	—	—	5	—	pF	

Transmit Analog Interface Characteristics

 ($V_{DD} = 2.7\text{ V to }3.8\text{ V}$, $T_a = -30^\circ\text{C to }+85^\circ\text{C}$)

Parameter	Symbol	Condition	Min.	Typ.	Max.	Unit
Input Resistance	R_{INX}	AIN+, AIN-	10	—	—	$M\Omega$
Output Load Resistance	R_{LGX}	GSX with respect to SG	20	—	—	$k\Omega$
Output Load Capacitance	C_{LGX}		—	—	30	pF
Output Amplitude	V_{OGX}		-0.7	—	+0.7	V
Offset Voltage	V_{OSGX}		Gain = 1	-20	—	+20

Receive Analog Interface Characteristics

 ($V_{DD} = 2.7\text{ V to }3.8\text{ V}$, $T_a = -30^\circ\text{C to }+85^\circ\text{C}$)

Parameter	Symbol	Condition	Min.	Typ.	Max.	Unit
Input Resistance	R_{INPW}	PWI	10	—	—	$M\Omega$
Output Load Resistance	R_{LVF}	VFRO with respect to SG	20	—	—	$k\Omega$
	R_{LAO}	AOUT+, AOUT- (each) with respect to SG	0.6	—	—	$k\Omega$
Output Load Capacitance	C_{LVF}	VFRO	—	—	30	pF
	C_{LAO}	AOUT+, AOUT-	—	—	50	pF
Output Amplitude	V_{OVF}	VFRO, $R_L = 20\text{ k}\Omega$ with respect to SG	-1.0	—	+1.0	V
	V_{OAO}	AOUT+, AOUT-, $R_L = 0.6\text{ k}\Omega$ with respect to SG	-1.0	—	+1.0	V
Offset Voltage	V_{OSVF}	VFRO with respect to SG	-100	—	+100	mV
	V_{OSAO}	AOUT+, AOUT-, Gain = 1 with respect to SG	-100	—	+100	mV

AC Characteristics

 (F_S = 8 kHz, V_{DD} = 2.7 V to 3.8 V, T_a = -30°C to +85°C)

Parameter	Symbol	Freq. (Hz)	Level (dBm0)	Condition	Min.	Typ.	Max.	Unit
Transmit Frequency Response	Loss T1	60	0		20	26	—	dB
	Loss T2	300			-0.15	+0.07	+0.2	
	Loss T3	1020			Reference			
	Loss T4	2020			-0.15	-0.01	+0.2	
	Loss T5	3000			-0.15	+0.15	+0.2	
	Loss T6	3400			0	0.4	0.8	
Receive Frequency Response	Loss R1	300	0		-0.15	-0.03	+0.2	dB
	Loss R2	1020			Reference			
	Loss R3	2020			-0.15	-0.02	+0.2	
	Loss R4	3000			-0.15	+0.15	+0.25	
	Loss R5	3400			0	0.56	0.8	
Transmit Signal to Distortion Ratio	SD T1	1020	3	*1	35	43	—	dB
	SD T2		0		35	41	—	
	SD T3		-30		35	38	—	
	SD T4		-40		28	30	—	
	SD T5		-45		23	25	—	
Receive Signal to Distortion Ratio	SD R1	1020	3	*1	36	43	—	dB
	SD R2		0		36	41	—	
	SD R3		-30		36	40	—	
	SD R4		-40		30	33.5	—	
	SD R5		-45		25	30	—	
Transmit Gain Tracking	GT T1	1020	3		-0.3	+0.01	+0.3	dB
	GT T2		-10		Reference			
	GT T3		-40		-0.3	0	+0.3	
	GT T4		-50		-0.6	-0.03	+0.6	
	GT T5		-55		-1.2	+0.15	+1.2	
Receive Gain Tracking	GT R1	1020	3		-0.3	-0.06	+0.3	dB
	GT R2		-10		Reference			
	GT R3		-40		-0.3	-0.02	+0.3	
	GT R4		-50		-0.6	-0.02	+0.6	
	GT R5		-55		-1.2	-0.27	+1.2	

*1 Psophometric filter is used.

 *2 Upper columns are specified for the μ -law, lower for the A-law.

AC Characteristics (Continued)

 (F_S = 8 kHz, V_{DD} = 2.7 V to 3.8 V, T_a = -30°C to +85°C)

Parameter	Symbol	Freq. (Hz)	Level (dBm0)	Condition	Min.	Typ.	Max.	Unit
Idle Channel Noise	Nidle T	—	—	A _{IN} = SG *1	— ^{*2}	-72.5	-68	dBm0p
	Nidle R	—	—	*1 *3	—	-70.5		
Absolute Level (Initial Difference)	AV T	1020	0	V _{DD} = 3.0 V T _a = 25°C *4	0.338	0.35	0.362	V _{rms}
	AV R				0.483	0.5	0.518	
Absolute Level (Deviation of Temperature and Power)	AV Tt	1020	0	V _{DD} = 2.7 V to 3.8 V T _a = -30 to 85°C *4	-0.2	—	+0.2	dB
	AV Rt				-0.2	—	+0.2	dB
Absolute Delay	Td	1020	0	A to A BCLK = 64 kHz	—	—	0.6	ms
Transmit Group Delay	t _{GD} T1	500	0	*5	—	0.19	0.75	ms
	t _{GD} T2	600			—	0.11	0.35	
	t _{GD} T3	1000			—	0.02	0.125	
	t _{GD} T4	2600			—	0.05	0.125	
	t _{GD} T5	2800			—	0.07	0.75	
Receive Group Delay	t _{GD} R1	500	0	*5	—	0.00	0.75	ms
	t _{GD} R2	600			—	0.00	0.35	
	t _{GD} R3	1000			—	0.00	0.125	
	t _{GD} R4	2600			—	0.09	0.125	
	t _{GD} R5	2800			—	0.12	0.75	
Crosstalk Attenuation	CR T	1020	0	TRANS → RECV	75	80	—	dB
	CR R			RECV → TRANS	70	76	—	

*1 Psophometric filter is used.

*2 Upper column is specified for the μ-law, lower for the A-law.

*3 Input "0" code to PCMIN.

*4 AVR is defined at VFRO output.

*5 With respect to minimum value of the group delay distortion

AC Characteristics (Continued)

 (F_S = 8 kHz, V_{DD} = 2.7 V to 3.8 V, T_a = -30°C to +85°C)

Parameter	Symbol	Freq. (Hz)	Level (dBm0)	Condition	Min.	Typ.	Max.	Unit
Discrimination	DIS	4.6 kHz to 72 kHz	0	0 to 4000 Hz	30	32	—	dB
Out-of-band Spurious	S	300 to 3400	0	4.6 kHz to 100 kHz	—	-37.5	-35	dBm0
Intermodulation Distortion	IMD	f _a = 470 f _d = 320	-4	2f _a - f _d	—	-52	-35	dBm0
Power Supply Noise Rejection Ratio	PSR T	0 to 50 kHz	50 mV _{PP}	*6	—	30	—	dB
	PSR R							
Digital Output Delay Time	t _{SD}	C _L = 100 pF + 1 LSTTL			20	—	200	ns
	t _{XD1}				20	—	200	
	t _{XD2}				20	—	200	
	t _{XD3}				20	—	200	

*6 Measured under idle channel noise.

TIMING DIAGRAM

PCM Data Input/Output Timing

Transmit Timing

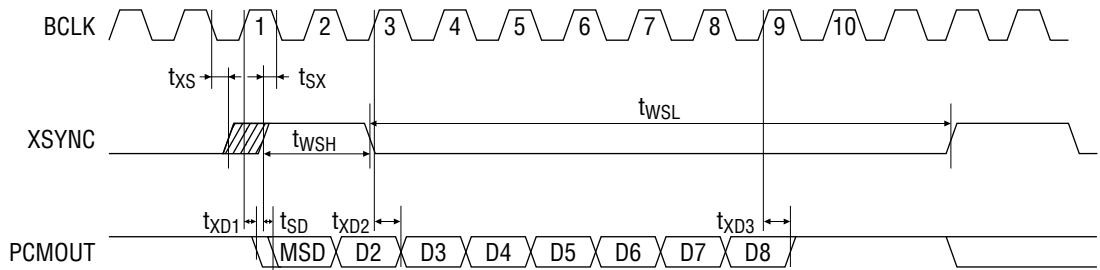

When $t_{XS} \leq 1/2 \cdot F_c$, the Delay of the MSD bit is defined as t_{XD1} .
 When $t_{SX} \leq 1/2 \cdot F_c$, the Delay of the MSD bit is defined as t_{SD} .

Receive Timing

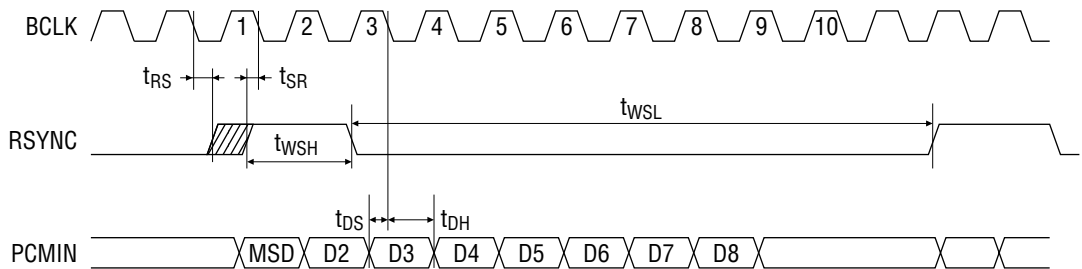
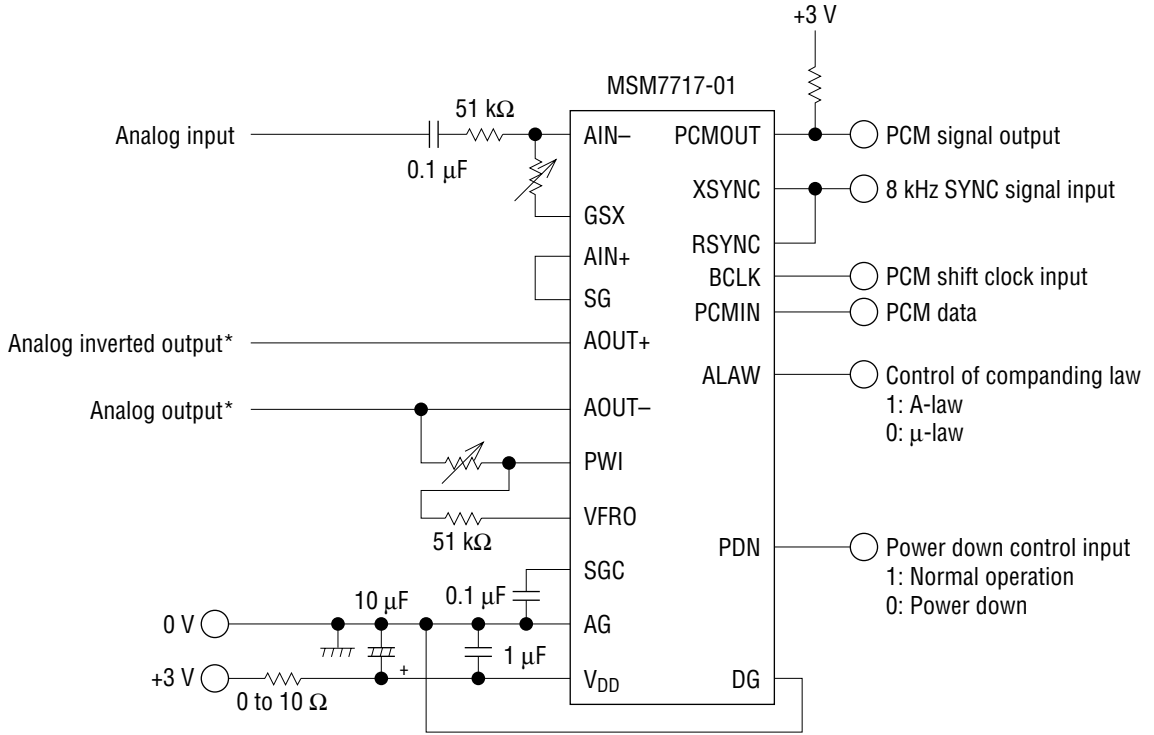

Figure 1 Basic Timing

APPLICATION CIRCUIT



* These output signals have amplitudes above and below the offset level of $V_{DD}/2$.

FREQUENCY CHARACTERISTICS ADJUSTMENT CIRCUIT

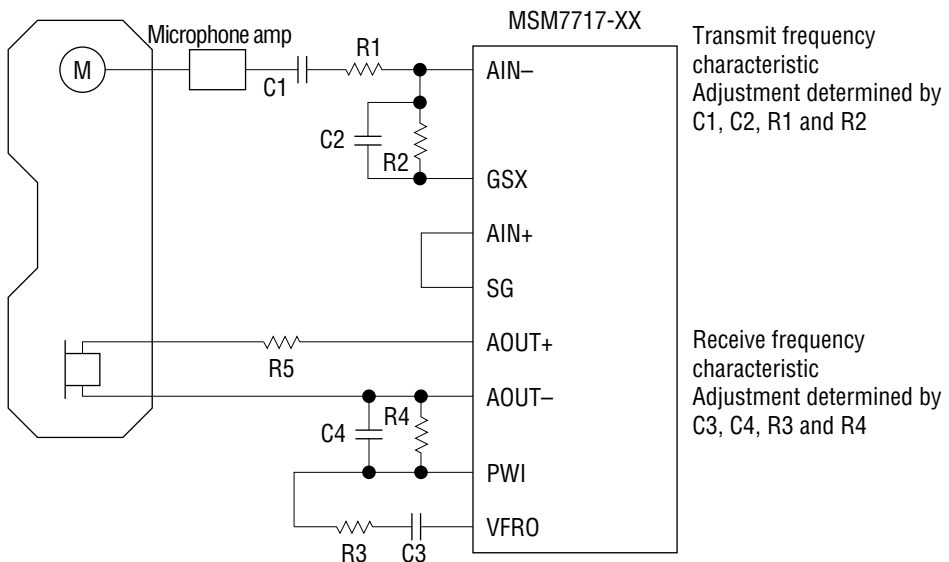

NOTES ON USE

- To ensure proper electrical characteristics, use bypass capacitors with excellent high frequency characteristics for the power supply and keep them as close as possible to the device pins.
- Connect the AG pin and the DG pin as close as possible. Connect to the system ground with low impedance.
- Mount the device directly on the board when mounted on PCBs. Do not use IC sockets. If the use of IC socket is unavoidable, use the short lead type socket.
- When mounted on a frame, use electro-magnetic shielding, if any electro-magnetic wave sources such as power supply transformers surround the device.
- Keep the voltage on the V_{DD} pin not lower than -0.3 V even instantaneously to avoid latch-up that may otherwise occur when power is turned on.
- Use a low noise (particularly, low level type of high frequency spike noise or pulse noise) power supply to avoid erroneous operation and the degradation of the characteristics of these devices.

PACKAGE DIMENSIONS

(Unit : mm)

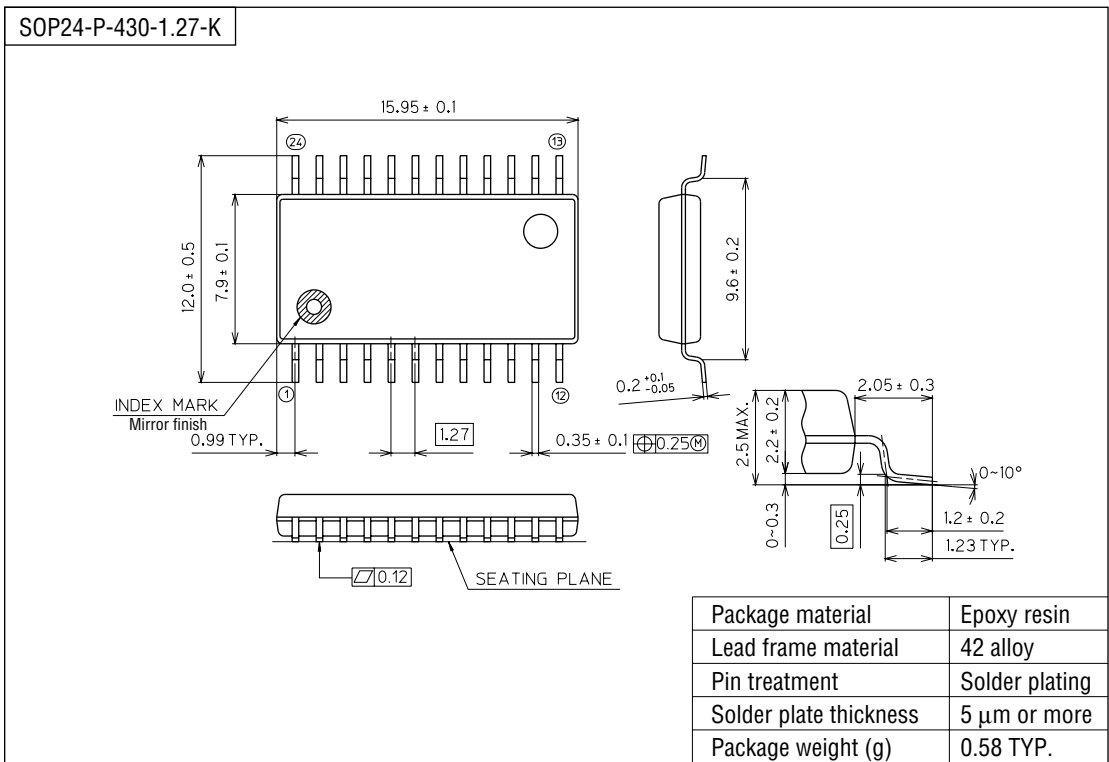

Notes for Mounting the Surface Mount Type Package

The SOP, QFP, TSOP, SOJ, QFJ (PLCC), SHP and BGA are surface mount type packages, which are very susceptible to heat in reflow mounting and humidity absorbed in storage. Therefore, before you perform reflow mounting, contact Oki's responsible sales person for the product name, package name, pin number, package code and desired mounting conditions (reflow method, temperature and times).

(Unit : mm)

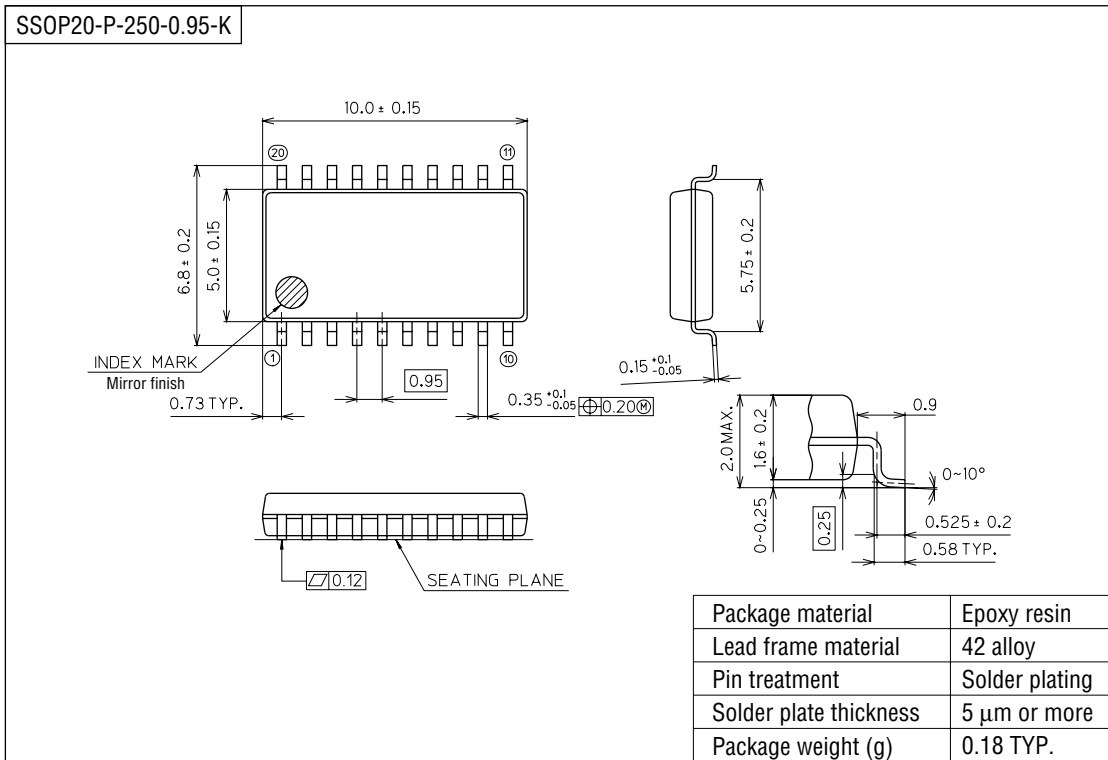

Notes for Mounting the Surface Mount Type Package

The SOP, QFP, TSOP, SOJ, QFJ (PLCC), SHP and BGA are surface mount type packages, which are very susceptible to heat in reflow mounting and humidity absorbed in storage. Therefore, before you perform reflow mounting, contact Oki's responsible sales person for the product name, package name, pin number, package code and desired mounting conditions (reflow method, temperature and times).

admatec

Schareggstrasse 3, CH-5506 Mägenwil

Tel. +41 62 896 00 48, Fax. +41 62 896 25 80

info@admatec.ch, www.admatec.ch