

OKI Semiconductor

FEDL2502-03

Issue Date: Aug. 9, 2004

ML2502

Recording/Playback LSI with On-Chip 128-Kbit-Cell Analog Storage Flash Memory

GENERAL DESCRIPTION

The ML2502 is a single-chip recording/playback LSI featuring an innovative Analog Multi-Level Storage technology that enables you to store non-compressed analog signals directly into the on-chip 128-Kbit-cell Flash memory.

The ML2502 can be a perfect fit for such applications as Voice-memos, Message Cards, toys and other consumer applications because of such features as low operating voltages (2.7 to 3.3 V), no backup requirement, and simplified operations eliminating an external MCU.

FEATURES

- Built-in 128-Kbit-cell Analog Storage Flash Memory
 - Programming/Erasing Cycles: 10,000 cycles
 - Data Retention Period: 10 years
- Recording/Playback Controls by Switch Input
- Number of Phrases to be recorded or played: 1 phrase or 2 phrases
- Recording/Playing Time (At $f_{SAM} = 6.4$ kHz)
 - In Dual-Phrase Recording/Playback Mode: Approx. 10 sec max. for each phrase (Entire memory divided into 2 phrases)
 - In Single-Phrase Recording/Playback Mode: Approx. 20 sec max. (Using the entire memory space by connecting REC1 to REC2 and PLAY1 to PLAY2)
- Sampling Frequency
 - Selectable; 4.0 kHz, 5.3 kHz or 6.4 kHz
- Built-in Microphone Amplifier with AGC (Automatic Gain Control)
- Built-in LPF
- Built-in Speaker Driver
 - Supports both a dynamic speaker and a piezo speaker through adjusting the voltage amplitude externally.
- No Oscillator Required (built-in oscillation circuit)
- Power Supply Voltage: 2.7 to 3.3 V
- Operating Temperature: -10 to +70°C
- Package: 30-pin plastic SSOP (SSOP30-P-56-0.65-K) (Product name: ML2502MB)
 - Die Form (Product name: ML2502WA)

BLOCK DIAGRAM

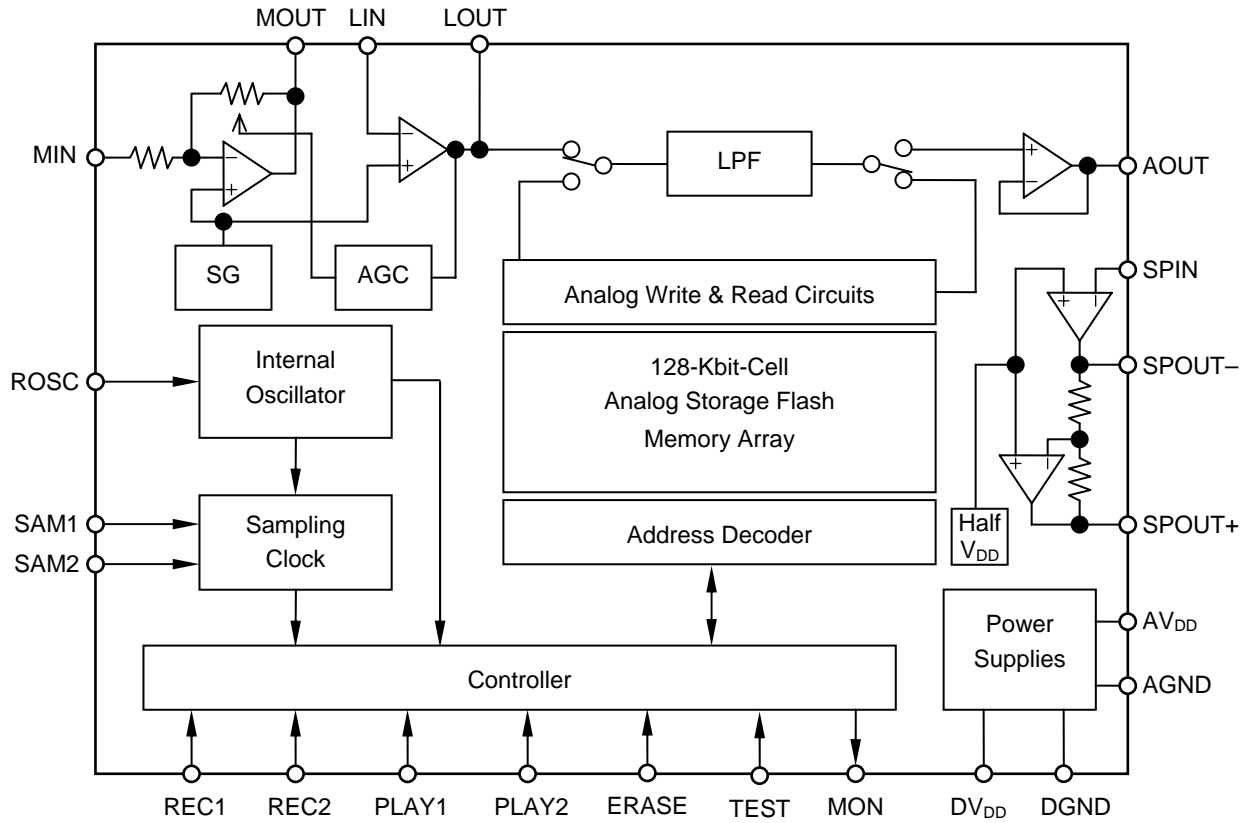

PIN LAYOUT (TOP VIEW)

PKG Code: SSOP30-P-56-0.65-K

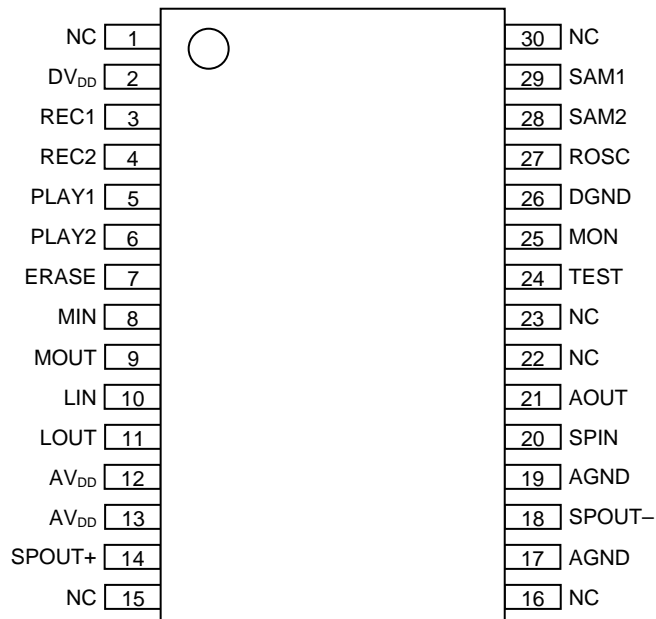

PIN DESCRIPTIONS

Symbol	I/O	Description															
REC1	I	Input Phrase 1 Record-Start signal to this pin. “H” level input lets the LSI start recording to the Phrase 1 memory area. Recording goes on while this pin stays “H”. To use the LSI in Single-Phrase Recording mode, connect this pin to the REC2 pin. The pin is pulled down internally.															
REC2	I	Input Phrase 2 Record-Start signal to this pin. “H” level input lets the LSI start recording to the Phrase 2 memory area. Recording goes on while this pin stays “H”. To use the LSI in Single-Phrase Recording mode, connect this pin to the REC1 pin. The pin is pulled down internally.															
PLAY1	I	Input Phrase 1 Play-Start signal to this pin. A “H” pulse input lets the LSI start playing Phrase 1. Re-inputting another “H” pulse during playing causes the LSI to stop playing half way. To use the LSI in Single-Phrase Play mode, connect this pin to the PLAY2 pin. The pin is pulled down internally.															
PLAY2	I	Input Phrase 2 Play-Start signal to this pin. A “H” pulse input lets the LSI start playing Phrase 2. Re-inputting another “H” pulse during playing causes the LSI to stop playing half way. To use the LSI in Single-Phrase Play mode, connect this pin to the PLAY1 pin. The pin is pulled down internally.															
ERASE	I	Input Erase-enable signal to this pin. Use this pin in combination with the REC1/REC2 pin. To erase Phrase 1/Phrase 2, input “H” level to the REC1/REC2 pin while inputting “H” level to the ERASE pin. The pin is pulled down internally.															
SAM1 SAM2	I	These pins are used to select a sampling frequency. <table border="1" style="margin-left: auto; margin-right: auto;"> <tbody> <tr> <td>SAM2</td> <td>L</td> <td>L</td> <td>H</td> <td>H</td> </tr> <tr> <td>SAM1</td> <td>L</td> <td>H</td> <td>L</td> <td>H</td> </tr> <tr> <td>Fs</td> <td>4.0 kHz</td> <td>5.3 kHz</td> <td>6.4 kHz</td> <td>Unused</td> </tr> </tbody> </table>	SAM2	L	L	H	H	SAM1	L	H	L	H	Fs	4.0 kHz	5.3 kHz	6.4 kHz	Unused
SAM2	L	L	H	H													
SAM1	L	H	L	H													
Fs	4.0 kHz	5.3 kHz	6.4 kHz	Unused													
MON	O	Outputs “H” level during recording, playing and erasing.															
ROSC	I	Insert a 33 k Ω (No more than $\pm 1\%$) resistor between the DGND and this pin. The value of this resistor determines the clock frequency used to control the LSI's internal operations. While in power-down state, it falls down to GND level.															
MIN	I	Input to the Microphone amplifier.															
MOUT	O	Output from the Microphone amplifier. Voltage amplitude is adjusted automatically to a proper output level by the internal AGC circuit.															
LIN	I	Input to the Line amplifier. Wired to the inverting input to the internal OP amplifier.															
LOUT	O	Output from the Line amplifier. Wired to the output from the internal OP amplifier. To configure an inverting amplifier circuit, add a resistor to the LIN and LOUT pin respectively.															
AOUT	O	Outputs analog signal for playback from this pin.															
SPIN	I	Input to the speaker driver. Voltage amplitude of the speaker driver can be determined by the value of the resistor inserted between the AOUT and SPIN pins.															
SPOUT+ SPOUT-	O	Outputs from the speaker driver. Connect a speaker using these two pins. These pins output two phase-reversed analog signals for playback.															
TEST	I	LSI testing pin. The pin must be wired to the GND.															
DV _{DD}	—	Digital power supply pin. Insert a 0.1 μ F or larger bypass capacitor between the DGND and this pin.															
DGND	—	Digital ground pin															
AV _{DD}	—	Analog power supply pin. Insert a 0.1 μ F or larger bypass capacitor between the AGND and this pin.															
AGND	—	Analog ground pin															

FUNCTIONAL DESCRIPTION

The ML2502 has 2 recording/playback modes; Dual-Phrase Recording/Playback Mode where the entire memory space is divided evenly into two areas and Single Phrase Recording/Playback Mode where the entire memory space is used for a single phrase recording/playing.

In Dual-Phrase Recording/Playback mode, the memory area from the top address to the center address is assigned to Phrase 1, while the memory area from the center address to the last address is assigned to Phrase 2.

You can record or play Phrase 1 using the REC1 and PLAY1 pins, and Phrase 2 using the REC2 and PLAY2 pins. Meanwhile, you can perform recording/playback operation with the REC1 pin connected to REC2 and the PLAY1 pin connected to PLAY2 in Single Phrase Recording/Playback mode.

The ML2502 is capable of storing the Recording-Stop address for each phrase in the on-chip Flash memory. For play operation, it automatically stops playing when the Stop address has been reached. Therefore, your application does not need any external MCU to control addressing.

Dual-Phrase Recording/Playback Mode

Phrase 1 Recording Operation

- (1) To power up the LSI and start recording Phrase 1 from the top address of the memory, keep inputting “H” level to the REC1 pin. Recording goes on while the REC1 pin stays “H”.
- (2) The LSI automatically stops recording when the center address of the memory has been reached.
- (3) When recording is complete, the LSI automatically powers down, entering a low-power-consumption state.
- (4) To stop recording phrase 1 half way, bring the REC1 pin to “L” level. When recording is complete, the LSI automatically powers down, entering a low-power-consumption state.

Note: Record operation lets the LSI overwrite the existing data in memory area of each phrase, which means the previous recording data is erased whenever new recording is made.

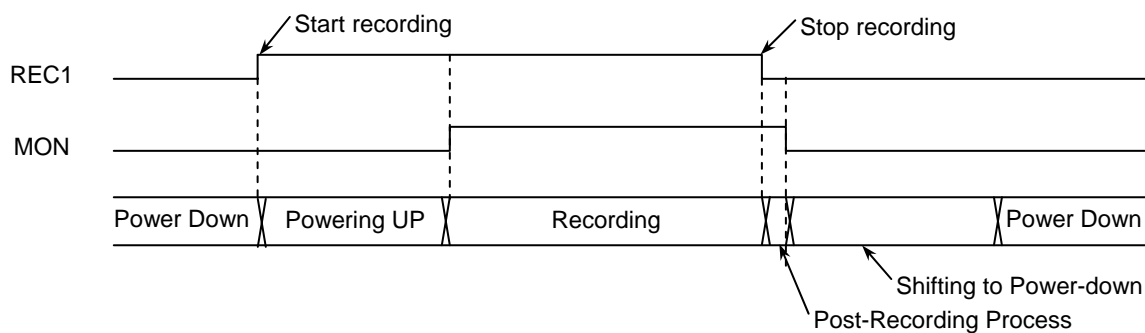

Figure 1 Phrase 1 Recording Operation Timing Chart

The following is some notes on stopping the recording operation:

• Note on stopping Phase 1 recording (1)

Any input to the REC2 pin while “H” level is being input to the REC1 pin is invalid.

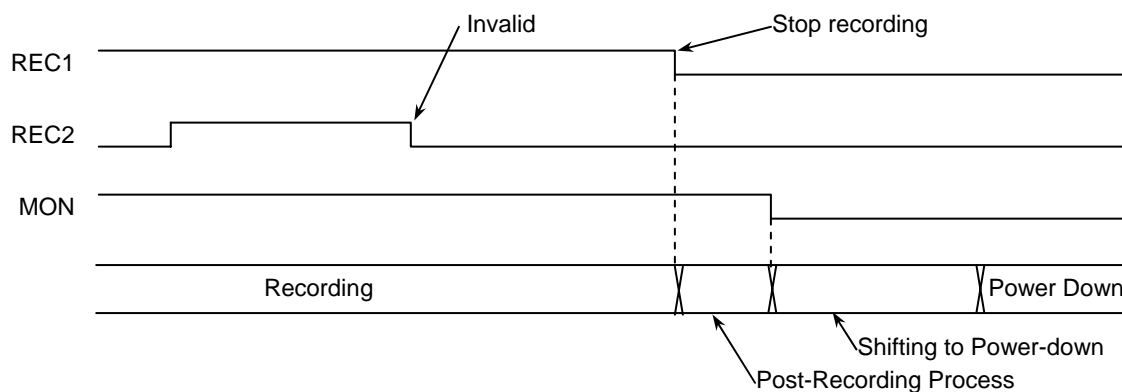

Figure 2 Phase 1 Recording Stop Operation Timing Chart (1)

• Note on stopping Phase 1 recording (2)

The LSI determines to stop recording when both the REC1 and REC2 pins turns to “L” level. Any “L” level input to the REC1 pin while the REC2 pin is staying at “H” level is invalid.

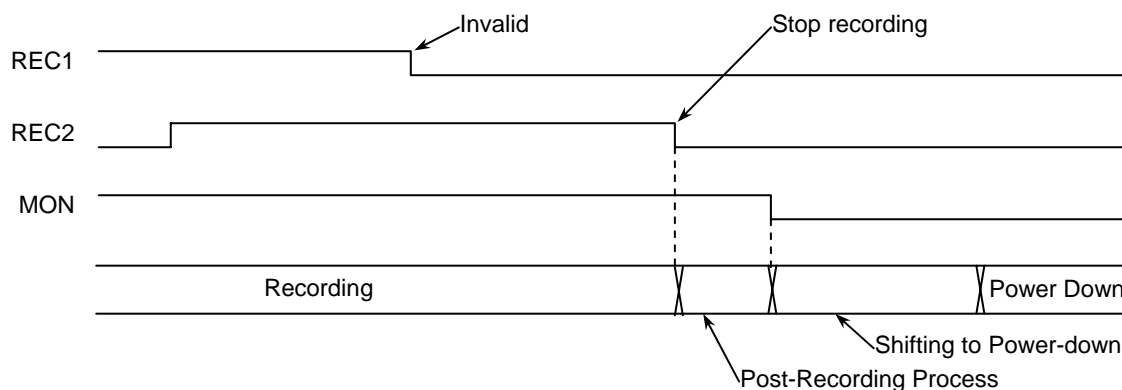

Figure 3 Phase 1 Recording Stop Operation Timing Chart (2)

• Note on stopping Phase 1 recording (3)

Any “H” level input to the PLAY1 or PLAY2 pin while “H” level is being input to the REC1 pin causes the LSI to stop recording.

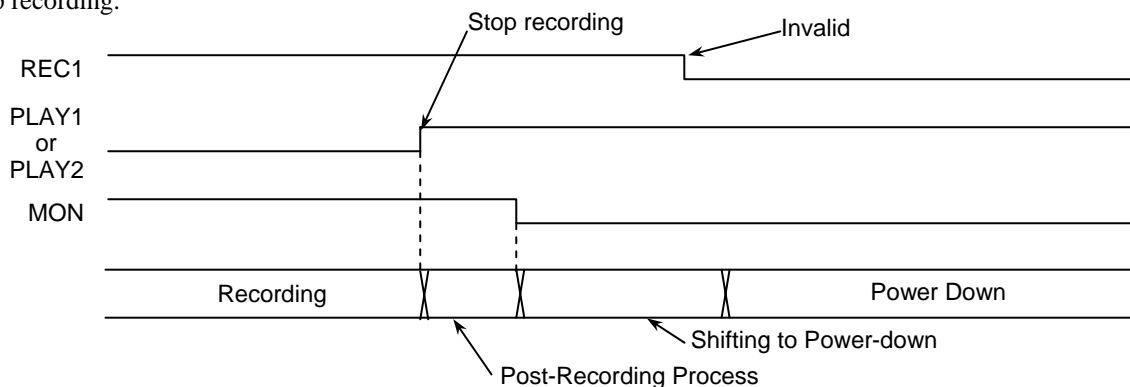

Figure 4 Phase 1 Recording Stop Operation Timing Chart (3)

Phrase 1 Play Operation

- (1) To power up the LSI and start playing from the top address of the memory, input a "H" pulse to the PLAY1 pin.
- (2) The LSI automatically stops playing when the last address of the recorded phrase has been reached.
- (3) When playing is complete, the LSI automatically powers down, entering a low-power-consumption state.
- (4) To stop playing Phrase 1 half way, input a "H" pulse to the PLAY1 or PLAY2 pin again. When playing is complete, the LSI automatically powers down, entering a low-power-consumption state.
- (5) During playback operation (after a "H" pulse input to start playing), the valid input signal is one to the PLAY1 or PLAY2 pin only and input signals to other pins are disregarded.

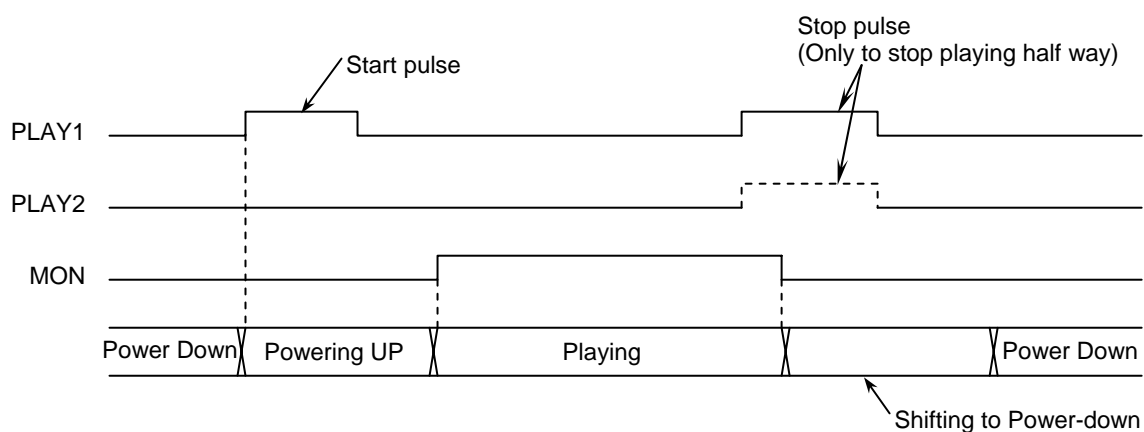

Figure 5 Phrase 1 Play Operation Timing Chart

Note: If you input a Start-Play pulse during the period when the LSI transits to power-down after stopping playback, such Start-Play pulse is disregarded.

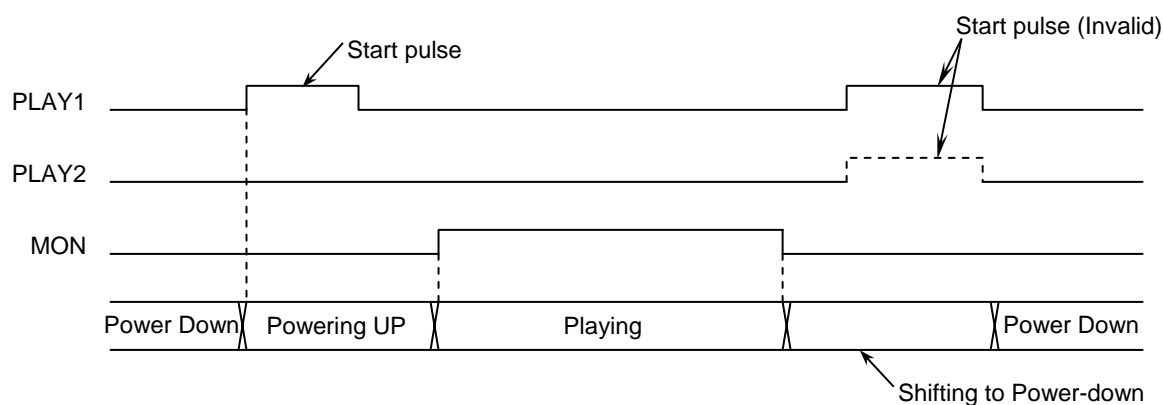

Figure 6 Phrase 1 Play Operation Timing Chart

Phrase 1 Erasing Operation

- (1) To start erasing Phrase 1, input a “H” pulse to the REC1 pin while inputting “H” level to the ERASE pin.
- (2) When erasing Phrase 1 is complete, the LSI automatically powers down, entering a low-power-consumption state.

Note: You can't stop erasing operation half way once getting started.

Technically speaking, erasing Phrase 1 means recording silence to a 250-address space starting from the top address of the memory. Therefore, if you perform play operation right after erasing, the LSI plays silence from the top address of the memory up to 250-address space and then stops playing automatically.

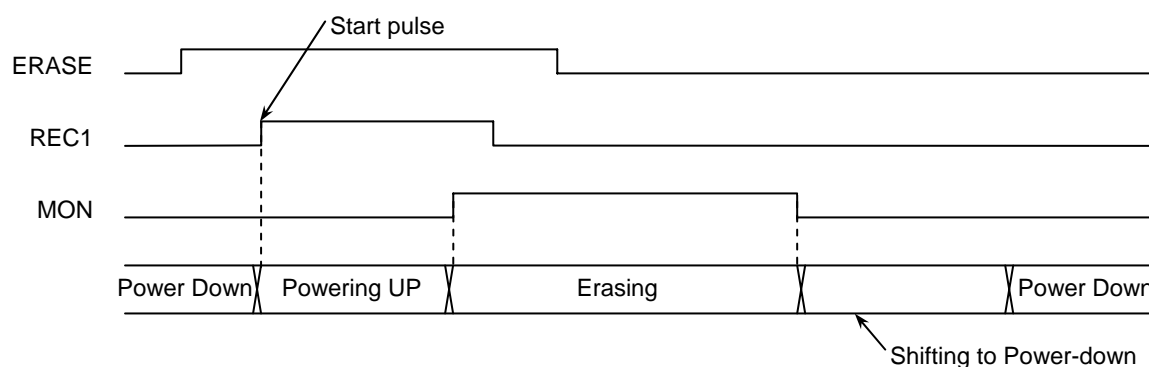

Figure 7 Phrase 1 Erasing Operation Timing Chart

Phrase 2 Recording Operation

- (1) To power up the LSI and start recording Phrase 2 from the center address of the memory, keep inputting “H” level to the REC2 pin. Recording goes on while the REC2 pin stays “H”.
- (2) The LSI automatically stops recording when the last address of the memory has been reached.
- (3) When recording is complete, the LSI automatically powers down, entering a low-power-consumption state.
- (4) To stop recording phrase 2 half way, bring the REC2 pin to “L” level. When recording is complete, the LSI automatically powers down, entering a low-power-consumption state.

Note: Recording operation lets the LSI overwrite the existing data in memory area of each phrase, which means the previously recorded data is erased whenever new recording is made.

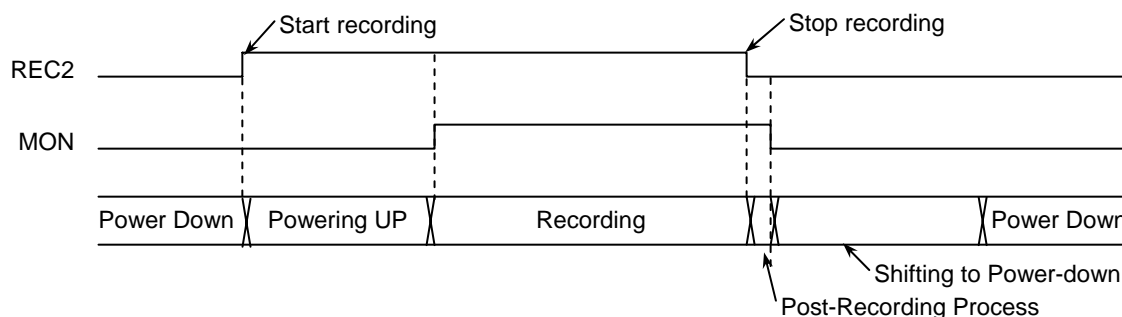

Figure 8 Phrase 2 Recording Operation Timing Chart

The following is some notes on stopping recording operation:

• **Note on stopping Phase 2 recording (1)**

Any input to the REC1 pin while “H” level is being input to the REC2 pin is invalid.

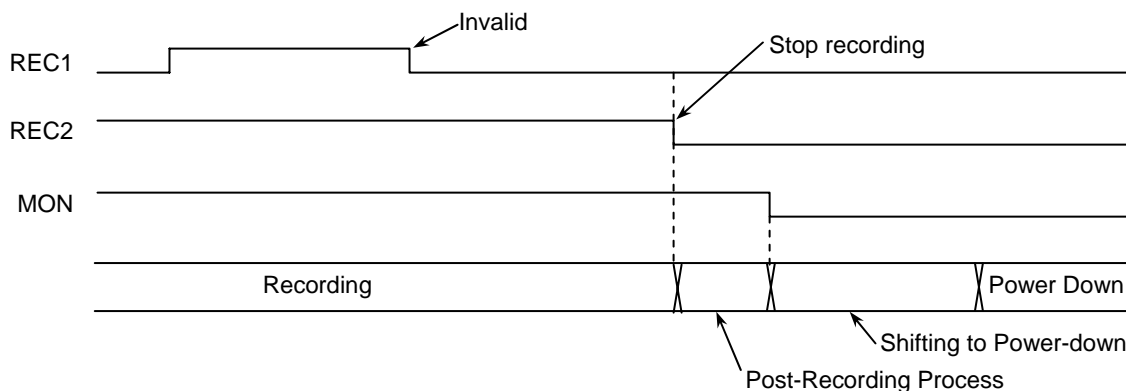

Figure 9 Phase 2 Recording Stop Operation Timing Chart (1)

• **Note on stopping Phase 2 recording (2)**

The LSI determines stopping the recording operation when both the REC1 and REC2 pins turn to “L” level. Any “L” level input to the REC2 pin while the REC1 pin is staying at “H” level is invalid.

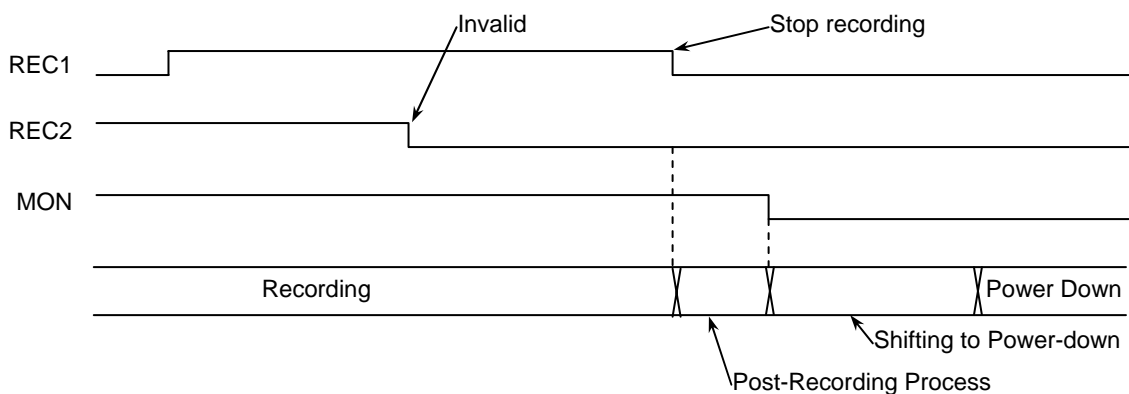

Figure 10 Phase 2 Recording Stop Operation Timing Chart (2)

• **Note on stopping Phase 2 recording (3)**

Any “H” level input to the PLAY1 or PLAY2 pin while “H” level is being input to the REC2 pin causes the LSI to stop recording.

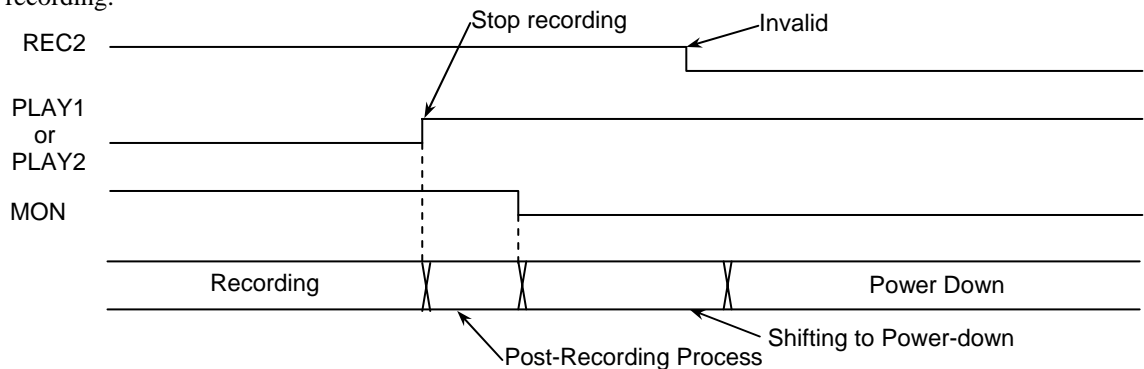

Figure 11 Phase 2 Recording Stop Operation Timing Chart (3)

Phrase 2 Playing Operation

- (1) To power up the LSI and start playing from the center address of the memory, input a "H" pulse to the PLAY2 pin.
- (2) The LSI automatically stops playing when the last address of the recorded phrase has been reached.
- (3) When playing is complete, the LSI automatically powers down, entering a low-power-consumption state.
- (4) To stop playing Phrase 2 half way, input a "H" pulse to the PLAY1 or PLAY2 pin again. When playing is complete, the LSI automatically powers down, entering a low-power-consumption state.
- (5) During playback operation (after a "H" pulse input to start playing), the valid input signal is one to the PLAY1 or PLAY2 pin only and input signals to other pins are disregarded.

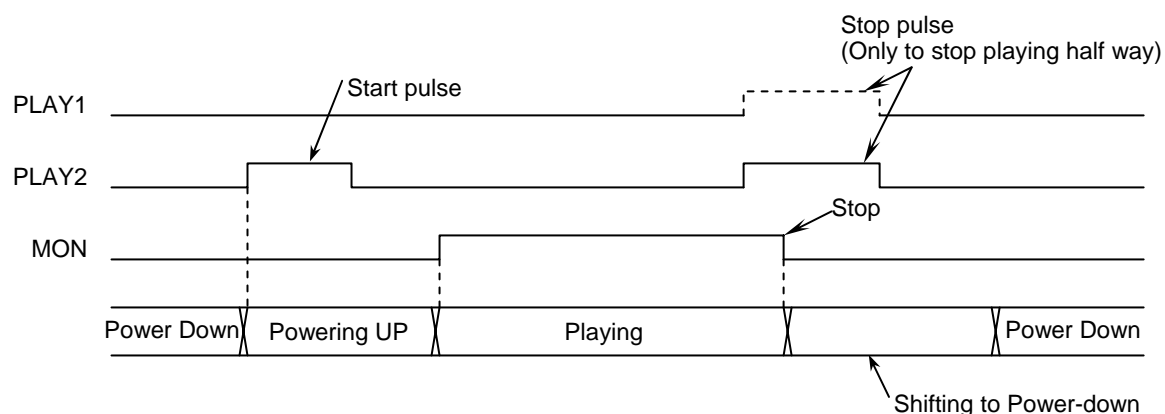

Figure 12 Phrase 2 Play Operation Timing Chart

Note: If you input a Start-Play pulse during the period when the LSI transits to power-down after stopping playback, such Start-Play pulse is disregarded.

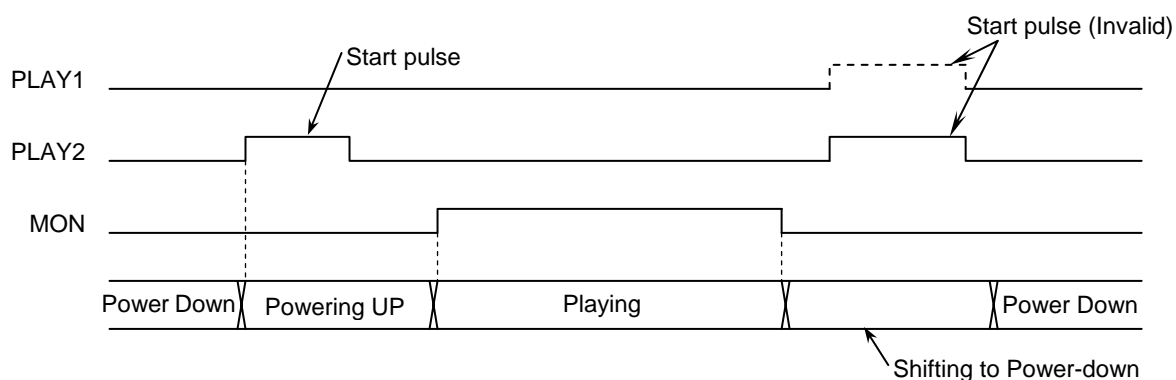

Figure 13 Phrase 1 Play Operation Timing Chart

Phrase 2 Erasing Operation

- (1) To start erasing Phrase 2, input a "H" pulse to the REC2 pin while inputting "H" level to the ERASE pin.
- (2) When erasing Phrase 2 is complete, the LSI automatically powers down, entering a low-power-consumption state.

Note: You can't stop erasing operation half way once getting started.

Technically speaking, erasing Phrase 2 means recording silence to a 250-address space starting from the center address of the memory. Therefore, if you perform the play operation right after erasing, the LSI plays silence from the center address of the memory up to 250-address space and then stops playing automatically.

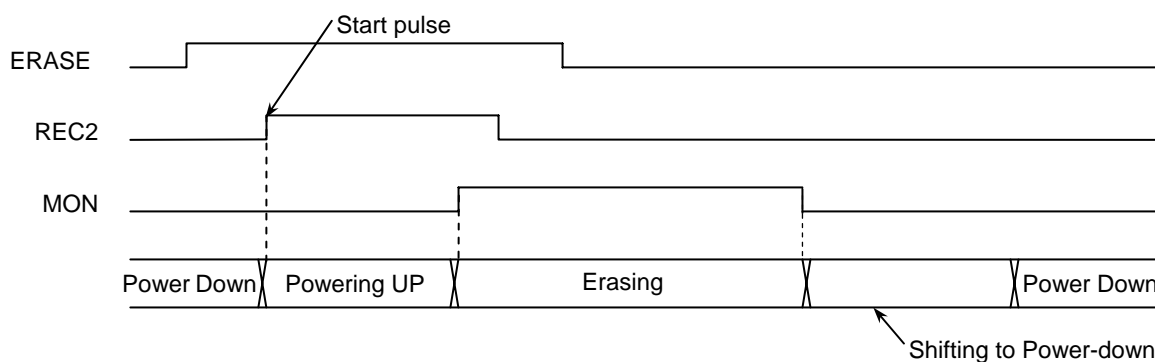

Figure 14 Phrase 2 Erasing Operation Timing Chart

Single-Phrase Recording/Playback Mode

Recording Operation

- (1) In Single-Phrase Recording/Playback mode, you can control the recording operation with the REC1 pin connected to the REC2 pin. To power up the LSI and start recording from the top address of the memory, keep inputting “H” level to the REC1 and REC2 pins. Recording goes on while the REC1 and REC2 pins stay “H”.
- (2) The LSI automatically stops recording when the last address of the memory has been reached.
- (3) When recording is complete, the LSI automatically powers down, entering a low-power-consumption state.
- (4) To stop recording half way, bring the REC1 and REC2 pins to “L” level. When recording is complete, the LSI automatically powers down, entering a low-power-consumption state.

Note 1: Recording operation lets the LSI overwrite the existing data, which means the previously recorded data is erased whenever new recording is made.

Note 2: Inputting a “H” pulse to the PLAY1 or PLAY2 pin during record operation causes the LSI to stop recording. To start recording again, bring the REC1 and REC2 pins to “L” level once and then input “H” level.

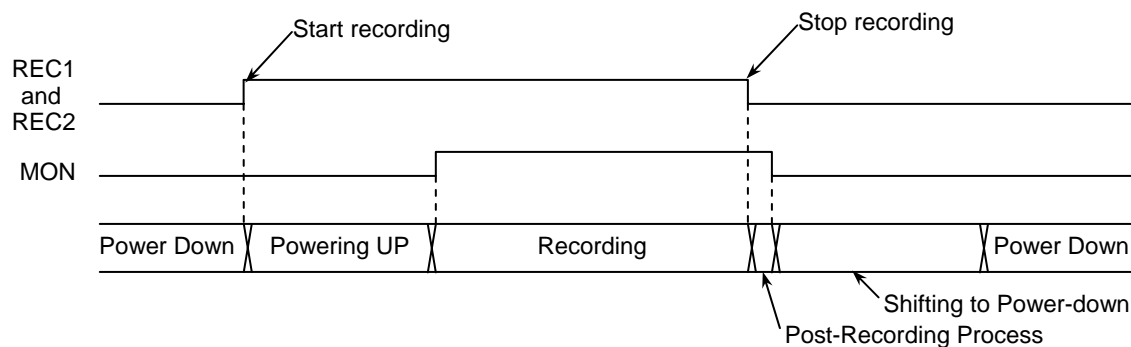

Figure 15 Timing Chart of Recording Operation in Single-Phrase Recording Mode

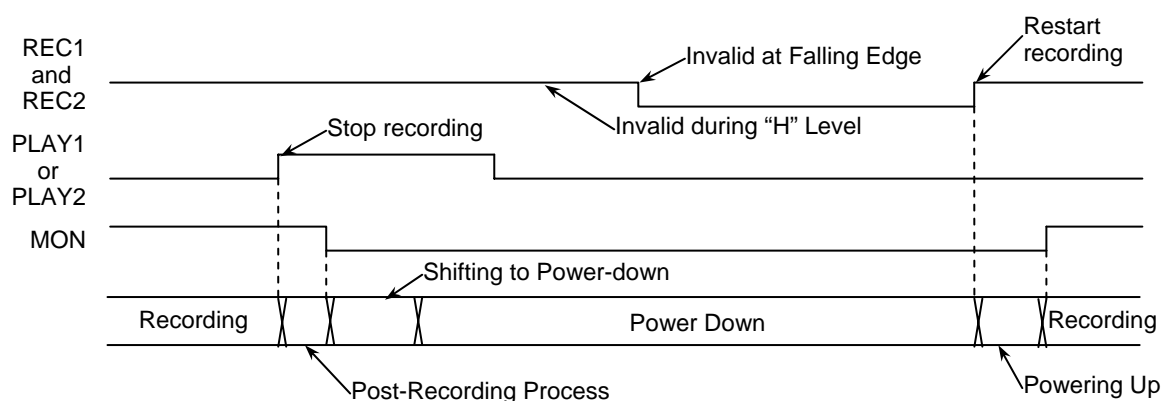

Figure 16 Timing Chart of Recording Stop Operation in Single-Phrase Recording Mode

Playing Operation

- (1) In Single-Phrase Recording/Playback mode, you can control the play operation with the PLAY1 pin connected to the PLAY2 pin. To power up the LSI and start playing from the top address of the memory, input a "H" pulse to the PLAY1 and PLAY2 pins.
- (2) The LSI automatically stops playing when the last address of the recorded phrase has been reached.
- (3) When playing is complete, the LSI automatically powers down, entering a low-power-consumption state.
- (4) To stop playing half way, input a "H" pulse to the PLAY1 and PLAY2 pins simultaneously. When playing is complete, the LSI automatically powers down, entering a low-power-consumption state.
- (5) During playback operation (after a "H" pulse input to start playing), valid input signal is one to the PLAY1 and PLAY2 pins only and input signals to other pins are disregarded.

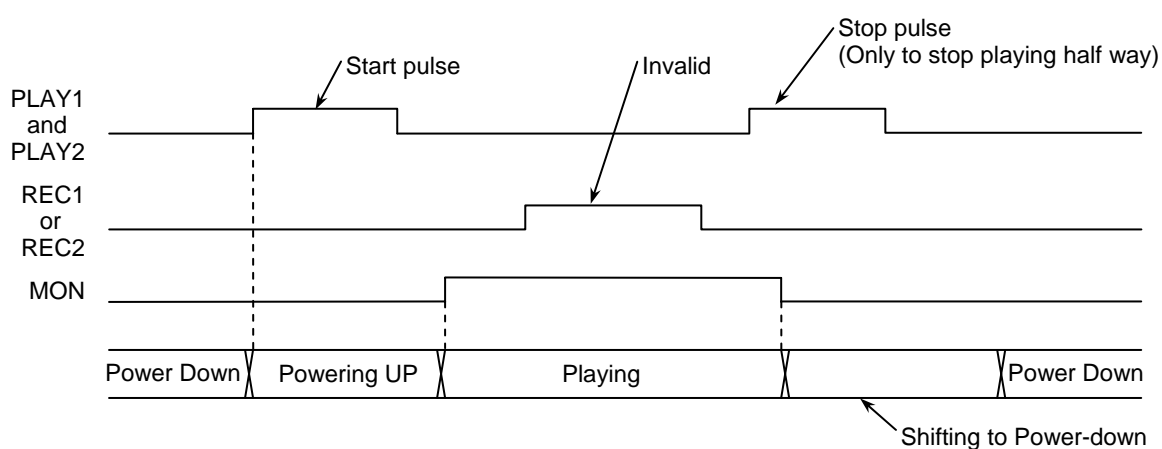

Figure 17 Timing Chart of Play Operation in Single-Phrase Play Mode

Note: If you input a Start-Play pulse during the period when the LSI transits to power-down after stopping playback, such Start-Play pulse is disregarded.

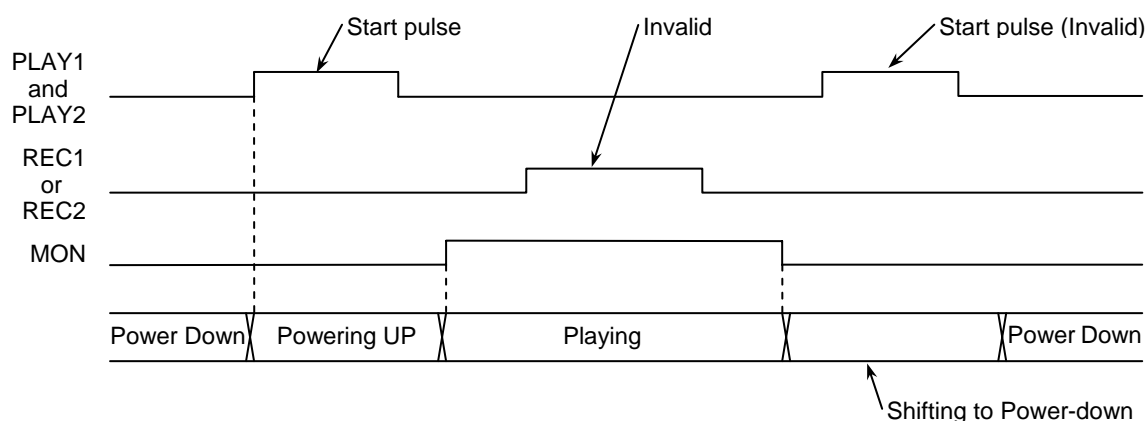

Figure 18 Timing Chart of Play Operation in Single-Phrase Play Mode

Erasing Operation

- (1) To start erasing, input a "H" pulse to the REC1 and REC2 pins simultaneously while inputting "H" level to the ERASE pin.
- (2) When erasing is complete, the LSI automatically powers down, entering a low-power-consumption state.

Note: You can't stop erasing operation half way once getting started.

Technically speaking, erasing means recording silence to a 250-address space starting from the top address of the memory. Therefore, if you perform play operation right after erasing, the LSI plays silence from the top address of the memory up to 250-address space and then stops playing automatically.

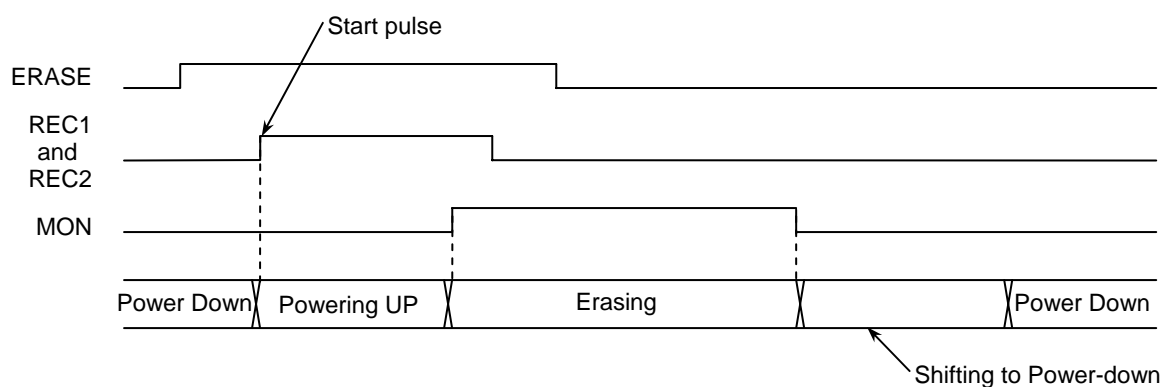

Figure 19 Timing Chart of Erasing Operation in Single-Phrase Recording/Playback Mode

Repeating Play Operation

- (1) Keep inputting "H" level to the PLAY1 or PLAY2 pin to repeat the play operation. To power up the LSI and start playing, input a "H" pulse to the PLAY1 or PLAY2 pin.
- (2) The LSI automatically repeats playing when the last address of the recorded phrase has been reached.
- (3) To stop repeating the play operation, bring the PLAY1 or PLAY2 pin to "L" level. The LSI automatically stops playing when the last address of the recorded phrase has been reached.
- (4) When playing is complete, the LSI automatically powers down, entering a low-power-consumption state.
- (5) To stop playing half way, input a "H" pulse again to the PLAY1 or PLAY2 pin after bringing the PLAY1 or PLAY2 pin to "L" level once. When playing is complete, the LSI automatically powers down, entering a low-power-consumption state.

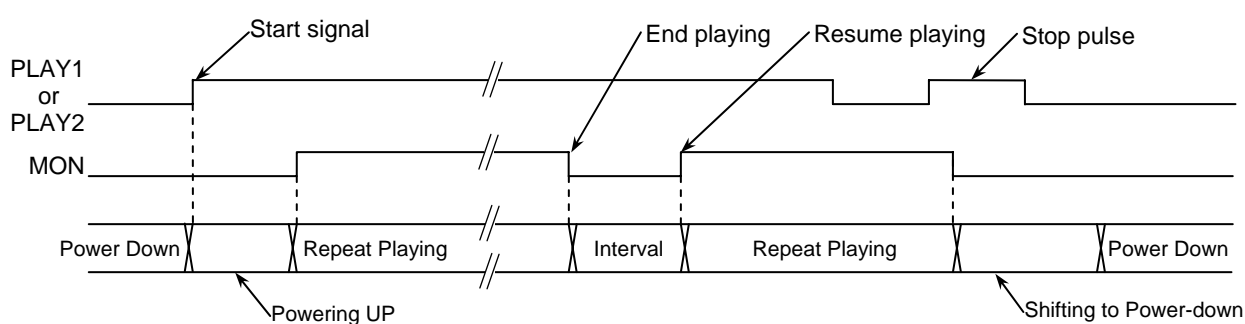

Figure 20 Timing Chart of Phrase 1 Play Repeat Operation

Note: During Play Repeat operation (i.e. while the PLAY1 or PLAY2 pin is staying at "H" level), input to the REC1 or REC2 pin causes the LSI to stop playing.

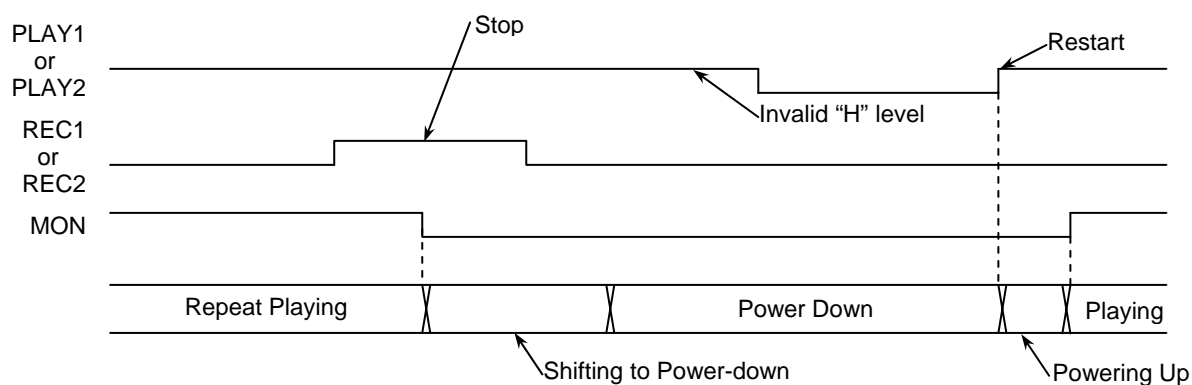

Figure 21 Timing Chart When Phrase 1 Play Repeat Operation is Forced to Stop

Designing Analog Input Amplifying Circuit Block

The ML2502 contains two amplifiers; a Microphone amplifier with AGC function and an OP amplifier for line input. Non-inverting input of each amplifier is connected internally to the analog reference SG (Signal Ground). The diagram below shows a sample amplifier circuit to amplify the input signal from a microphone. Output signal from the LOUT pin is input to the internal LPF as a source signal for recording.

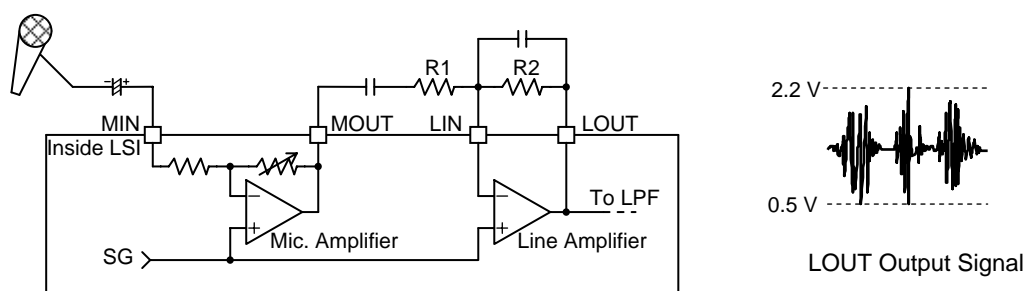

Figure 22 Designing Analog Input Amplifying Circuit Block

The voltage amplitude of the microphone amplifier is adjusted automatically between 8 times and 28 times so that the output voltage from the LOUT pin is not above 2.5 V.

It is recommended that you adjust the output from the Line amplifier with R1 and R2 resistors to let the LOUT voltage stays within 0.5 to 2.2 V.

The minimum value of output load resistor for the MOUT and LOUT pins is 200 k Ω . So, use a 200 k Ω or above value for R2, feedback resistor of the Line amplifier.

In case that you use the Line amplifier only without using the microphone amplifier, keep the MIN and MOUT pins open as shown in the diagram below.

Even if you don't need to amplify the source signal input, you must use the Line amplifier. In such case, use a 200 k Ω resistor for both R1 and R2 to set the amplitude of the Line amplifier to 1:1.

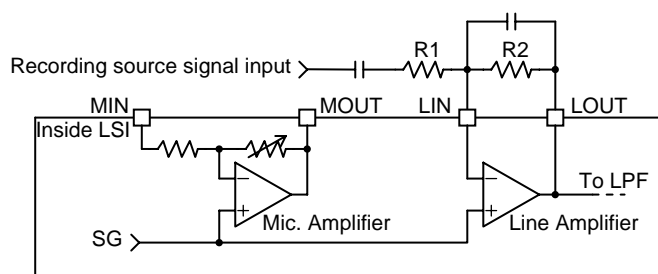

Figure 23 Analog Input Amplifying Circuit When Mic. Amplifier is not Used

Designing Analog Output Amplifying Circuit Block

The ML2502 has a built-in speaker driver that can directly drive an external speaker. Design your application circuit using resistors, capacitors and a speaker, as shown below.

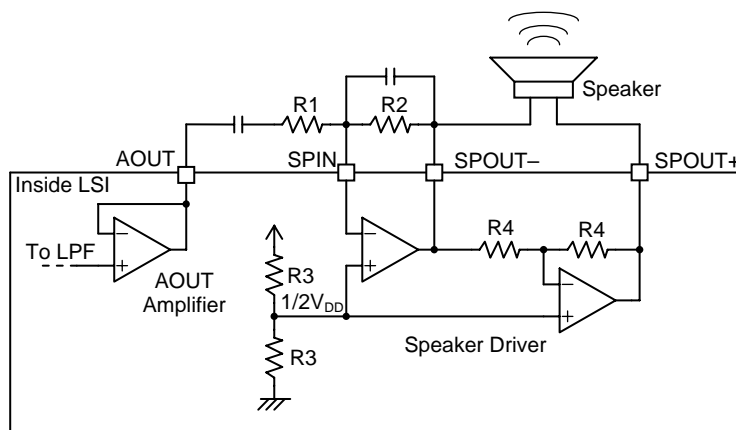

Figure 24 Designing Analog Output Amplifying Circuit Block

The AOUT pin outputs the analog playback signal having the signal amplitude equivalent to that from the LOUT pin for recording. Be sure to make an AC coupling as shown in the above diagram when the output signal from the AOUT pin is input to the speaker driver.

You can adjust the sound level by changing the ratio of R1:R2 that determines the amplitude of the speaker driver. The LSI outputs the phase-inverting signal of the same amplitude to the SPOUT+ pin with that to the SPOUT- pin. You can also use a circuit block as shown below to connect a speaker, but the output sound level gets lower compared with the above circuit block. You can adjust the sound level by changing the R1:R2 ratio just as you do with the above. An external speaker must be wired to the SPOUT+ pin when you use this type of circuit block.

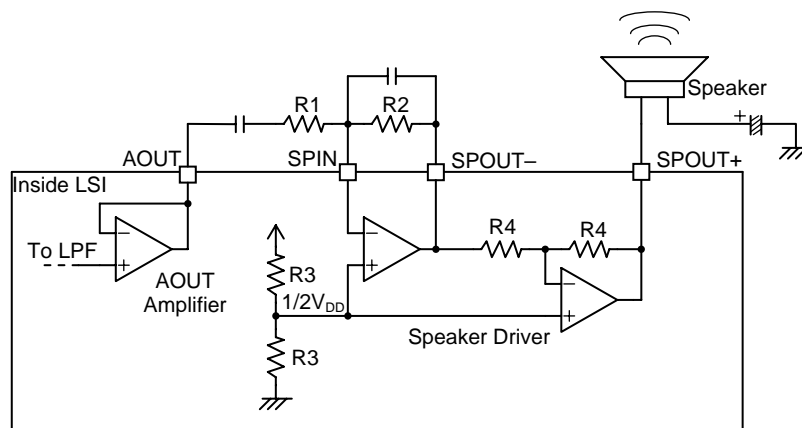

Figure 25 Speaker Connection

If you don't use the built-in speaker driver, connect the SPIN pin to the AGND or AV_{DD} and keep the SPOUT+ and SPOUT- pins open, as shown in the figure below.

When you connect an external speaker driver to the AOUT pin, be sure to make an AC coupling.

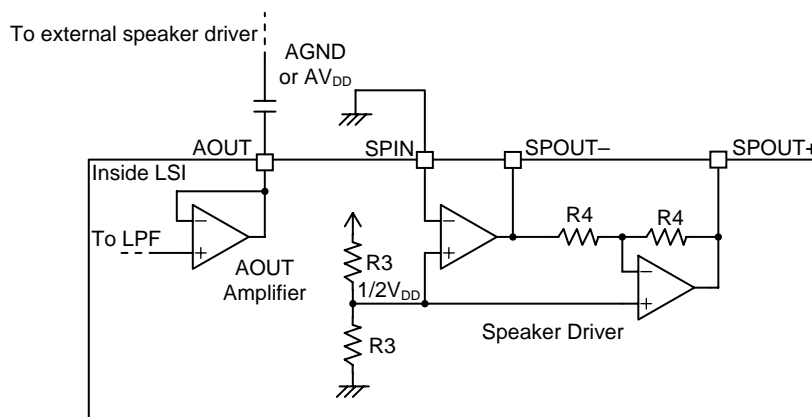

Figure 26 Wiring When the Internal Speaker Driver is Unused

LPF Characteristics

The ML2502 has a built-in 4-stage LPF utilizing Switched Capacitor Filter (SCF) technology. The SCF's attenuation is -40 dB and its cut-off frequency and frequency characteristics can vary in proportion to the sampling frequency. The cut-off frequency is set at 4/10 of the sampling frequency.

The following figures show Frequency Characteristics of the SCF at 6.4 kHz sampling frequency.

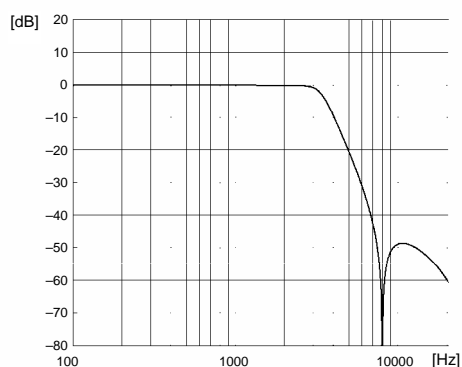

Figure 27 SCF Frequency Characteristics

Power Supply Circuit Block

As shown in the figure below, the supply to the ML2502 should come from a single power source and be divided into the analog and digital sections through wiring.

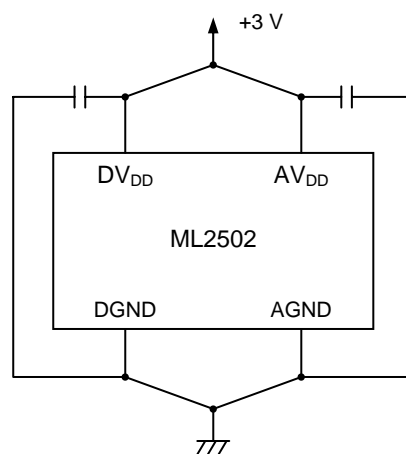

Figure 28 Power Supply Circuit Block

The following are some “Do Not” examples that you should avoid.

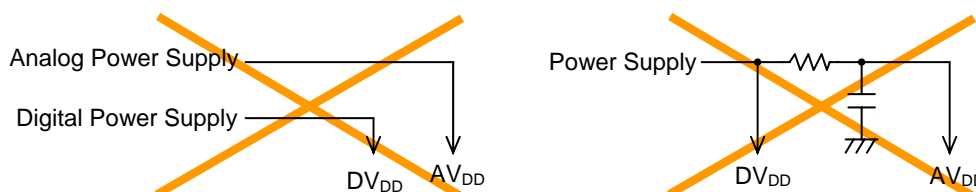

Figure 29 “Do Not” Wiring Samples

ABSOLUTE MAXIMUM RATINGS

Parameter	Symbol	Condition	Rating	Unit	Description
Power Supply Voltage	V_{DD}	$T_a = 25^\circ\text{C}$	-0.3 to +6.0	V	—
Input Voltage	V_{IN}		-0.3 to $V_{DD}+0.3$	V	—
Power Drain Allowance	P_D		533	mW	SSOP Package
Storage Temperature	T_{STG}	—	-55 to +150	$^\circ\text{C}$	—

RECOMMENDED OPERATING CONDITIONS

Parameter	Symbol	Condition	Range	Unit
Power Supply Voltage	V_{DD}	DGND = AGND = 0 V	2.7 to 3.3	V
Operating Temperature	T_{OP}	—	-10 to +70	$^\circ\text{C}$
ROSC Resistor Value	R_{ROSC}	$T_a = 25^\circ\text{C}$	33 ($\pm 1\%$)	$\text{k}\Omega$

ELECTRICAL CHARACTERISTICS**DC Characteristics**DVDD = AVDD= 2.7 to 3.3 V, DGND = AGND = 0 V, $T_a = -10$ to $+70^\circ\text{C}$

Parameter	Symbol	Condition	Min.	Typ.	Max.	Unit
"H" Input Voltage	V_{IH}	DGND = AGND = 0 V	$0.8 \times V_{DD}$	—	—	V
"L" Input Voltage	V_{IL}	—	—	—	$0.2 \times V_{DD}$	V
"H" Output Voltage	V_{OH}	$I_{OH} = -40 \text{ A}$	$V_{DD}-0.3$	—	—	V
"L" Output Voltage	V_{OL}	$I_{OL} = 2 \text{ mA}$	—	—	0.45	V
"H" Input Current (*1)	I_{IH1}	$V_{IH} = V_{DD}$	—	—	10	μA
"L" Input Current (*1)	I_{IL1}	$V_{IL} = 0 \text{ V}$	-10	—	—	μA
"H" Input Current (*2)	I_{IH2}	$V_{IH} = 3.0 \text{ V}$	10	—	100	μA
"L" Input Current (*2)	I_{IL2}	$V_{IL} = 0 \text{ V}$	-10	—	—	μA
Supply Current (Operating)	I_{DD}	Output from SPOUT No Load	—	22	40	mA
Supply Current (Power Down)	I_{DDS}	—	—	0	10	μA

Note *1: Applicable to input pins without a pull-down resistor.

Note *2: Applicable to input pins (REC1, REC2, PLAY1, PLAY2 and ERASE) with a pull-down resistor.

AC Characteristics

DVDD = AVDD= 2.7 to 3.3 V, DGND = AGND = 0 V, Ta = -10 to +70°C

Parameter	Symbol	Condition	Min.	Typ.	Max.	Unit
Supply Voltage Rise Time (0 to 2.5 V)	t _{VRS}	—	—	—	100	ms
Power-On Resetting Time	t _{POR}	—	—	—	10	ms
Min. "H" Pulse Width for REC-Start Input	t _{WRECST}	—	287	—	—	ms
Min. "L" Pulse Width for REC-Stop Input	t _{WRECSP}	f _{SAMP} = 4.0 kHz	69.2	—	—	ms
		f _{SAMP} = 5.3 kHz	52.0	—	—	ms
		f _{SAMP} = 6.4 kHz	43.2	—	—	ms
Min. Pulse Width for PLAY-Start Input	t _{WPLYST}	—	16.9	—	—	ms
Min. Pulse Width for PLAY-Stop Input	t _{WPLYSP}	f _{SAMP} = 4.0 kHz	69.2	—	—	ms
		f _{SAMP} = 5.3 kHz	52.0	—	—	ms
		f _{SAMP} = 6.4 kHz	43.2	—	—	ms
REC1/REC2 Input Min. Pulse Width for ERASE-Start	t _{WERSST}	—	16.9	—	—	ms
ERASE Input – REC1/REC2 Input Setup Time	t _{WERS}	—	0	—	—	μs
ERASE Input – REC1/REC2 Input Holding Time	t _{WERSH}	—	0	—	—	μs
Powering Up Time 1 (in ERASE operation)	t _{WS1}	—	14.3	15.6	16.9	ms
Powering Up Time 2	t _{WS12}	—	244	266	287	ms
Max. Recording/Playing Time (In Single-Phrase Recording/Playback Mode)	t _{WRP}	f _{SAMP} = 4.0 kHz	29.4	32	34.6	s
		f _{SAMP} = 5.3 kHz	22.0	24	26.0	s
		f _{SAMP} = 6.4 kHz	18.4	20	21.6	s
Erase Executing Time	t _{WE}	—	489	532	575	ms
MON Output Fall Time (Max.) at Stopping Recording Operation	t _{WS3}	f _{SAMP} = 4.0 kHz	—	—	322	ms
		f _{SAMP} = 5.3 kHz	—	—	305	ms
		f _{SAMP} = 6.4 kHz	—	—	297	ms
Power-Down Transition Time	t _{WS4}	—	14.3	15.6	16.9	ms

Analog Block Characteristics

DVDD = AVDD= 2.7 to 3.3 V, DGND = AGND = 0 V, Ta = -10 to +70°C

Parameter	Symbol	Condition	Min.	Typ.	Max.	Unit
MIN Input Resistance	R _{MIN}	—	4.2	6	7.8	kΩ
Mic. Amp. Voltage Gain Range	G _{MIC}	—	8	—	28	V/V
LIN Input Impedance	R _{IOP}	—	1	—	—	MΩ
Line Amp. Open Loop Gain	G _{OLINE}	f _{IN} = 0 to 4 kHz	40	—	—	dB
MOUT/LOUT/AOUT Output Voltage at Powering-up and Powering-down	V _{MOTP} V _{LOTP} V _{AOTP}	Between t _{WS12} and t _{WS4}	1.25	1.35	1.45	V
SPOUT+/- Output Voltage at Powering-up and Powering-down	V _{SPOTP} V _{SNOTP}	Between t _{WS12} and t _{WS4}	1/2V _{DD} -0.3	1/2V _{DD}	1/2V _{DD} +0.3	V
MOUT/LOUT Load Resistance	R _{L1}	—	200	—	—	kΩ
AOUT Load Resistance	R _{L2}	—	50	—	—	kΩ
SPOUT+/SPOUT- Amp. Open Loop Gain	G _{OSP}	f _{IN} = 0 to 4 kHz	40	—	—	dB
SPOUT+/SPOUT- Voltage Gain	G _{SPC}	—	0.95	1	1.05	V/V
SPIN Input Impedance	R _{ISP}	—	1	—	—	MΩ
SPOUT+/- Output "H" Voltage	V _{SPH}	I _{OH} = 10 mA	V _{DD} -0.25	—	—	V
SPOUT+/- Output "L" Voltage	V _{SPL}	I _{OL} = -10 mA	—	—	0.25	V
SPOUT Output Offset Voltage	V _{OFF}	Play with No Signal	—	—	±0.1	V
SPOUT Output Load Impedance	R _{SPO}	—	16	—	—	Ω
SPOUT Peak Output Load Current	I _{SPO}	—	—	—	±125	mA

TIMING DIAGRAMS

Digital Block

•Power-On

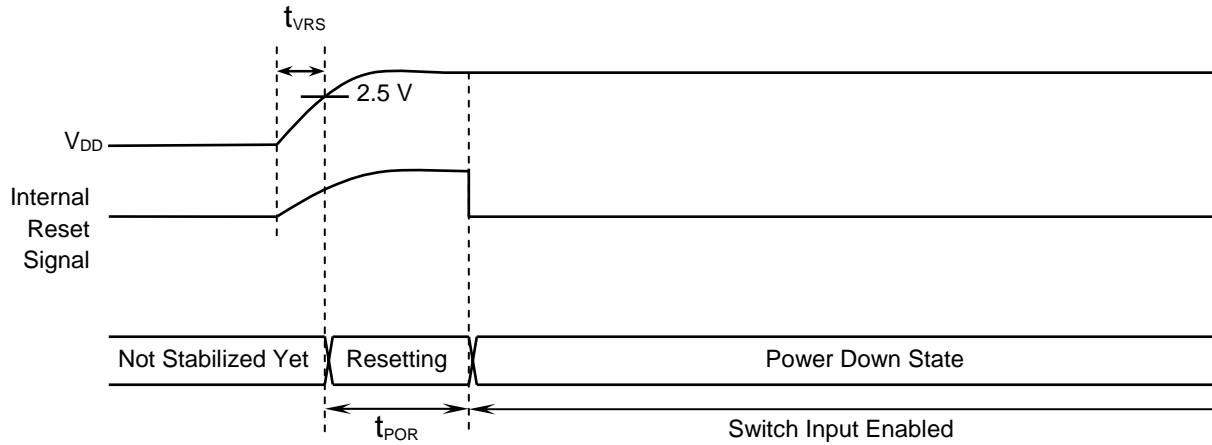

•Start Recording Phase 1

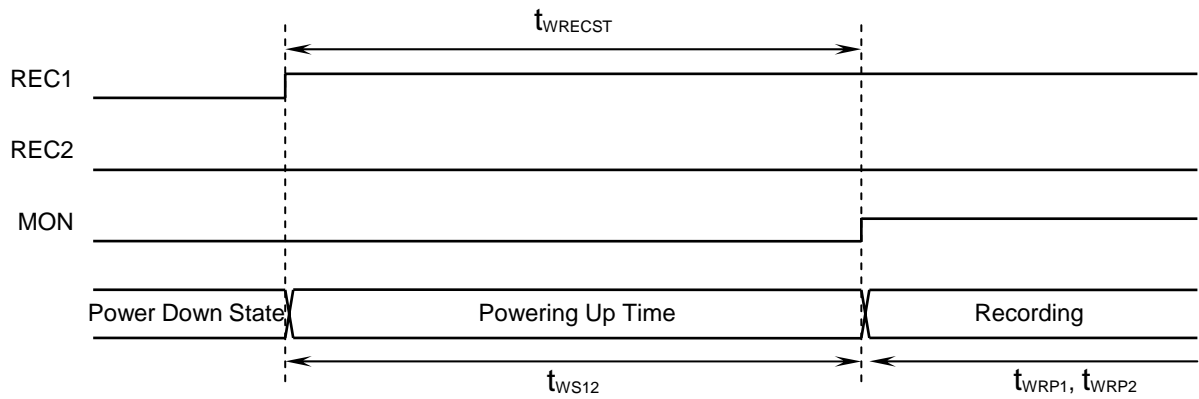

•End Recording Phase 1 (When the last address of the phrase has been reached)

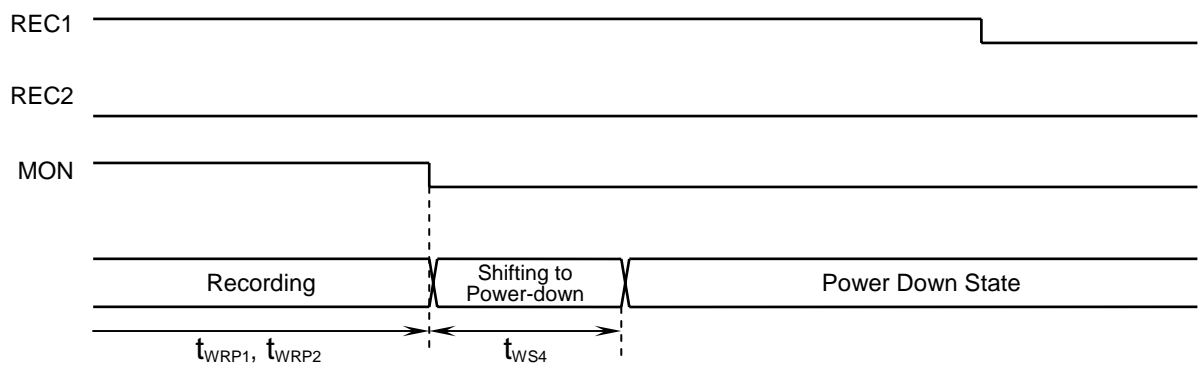

•Stop Recording Phrase 1 (When recording is stopped half way)

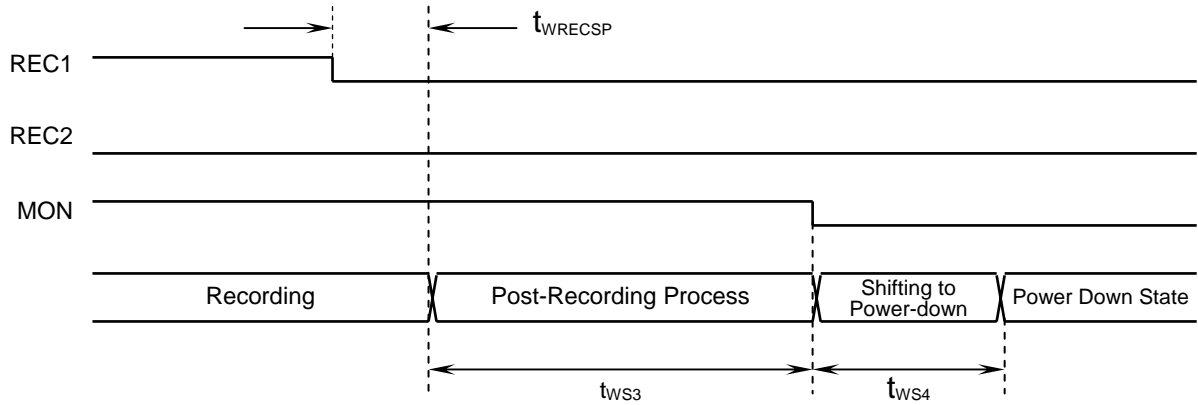

•Start Playing Phrase 1

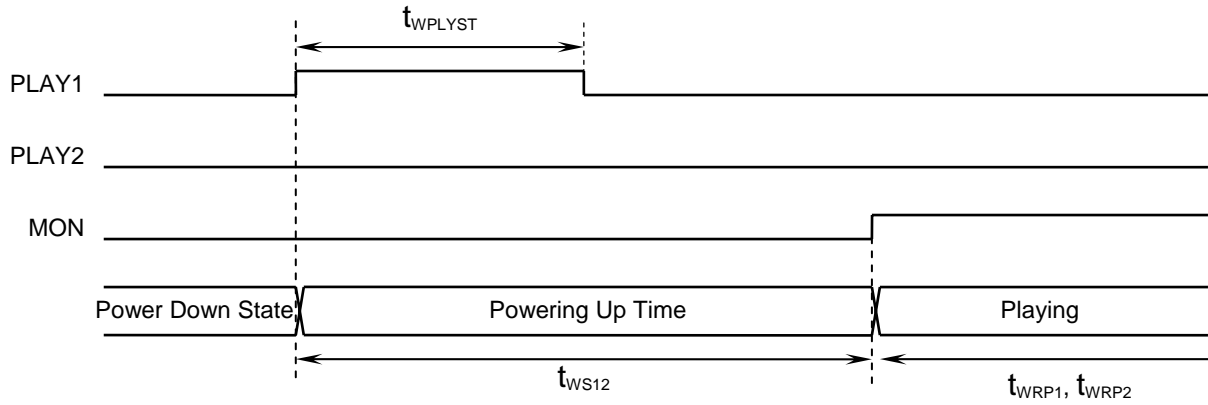

•End Playing Phrase 1 (When the last address of the recorded phrase has been reached)

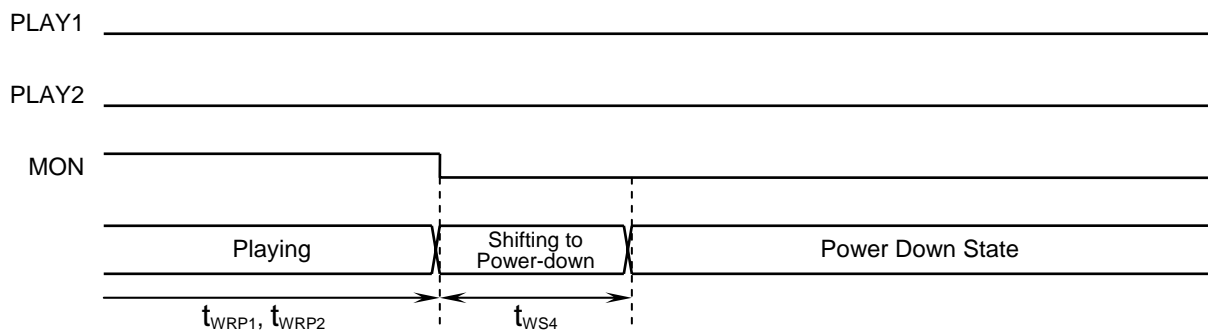

•Stop Playing Phrase 1 (When playing is stopped half way)

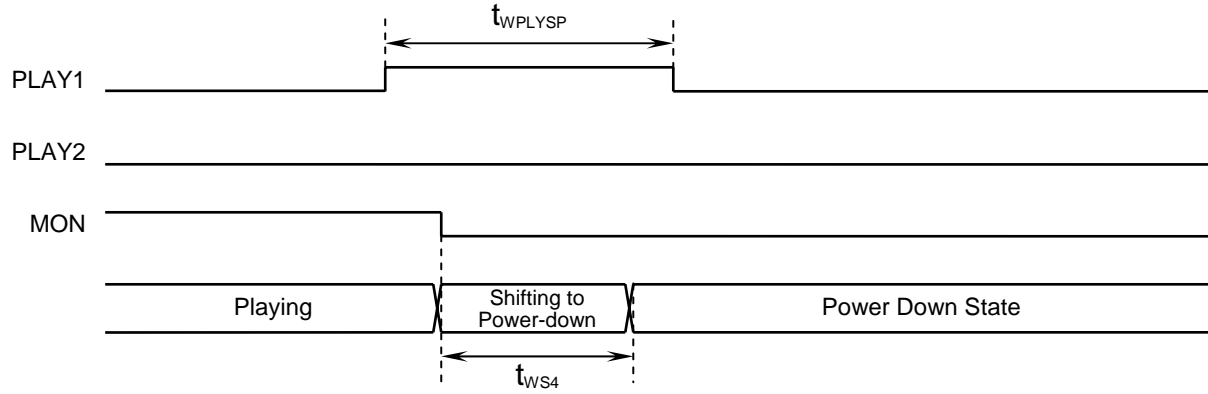

•Start Erasing Phrase 1

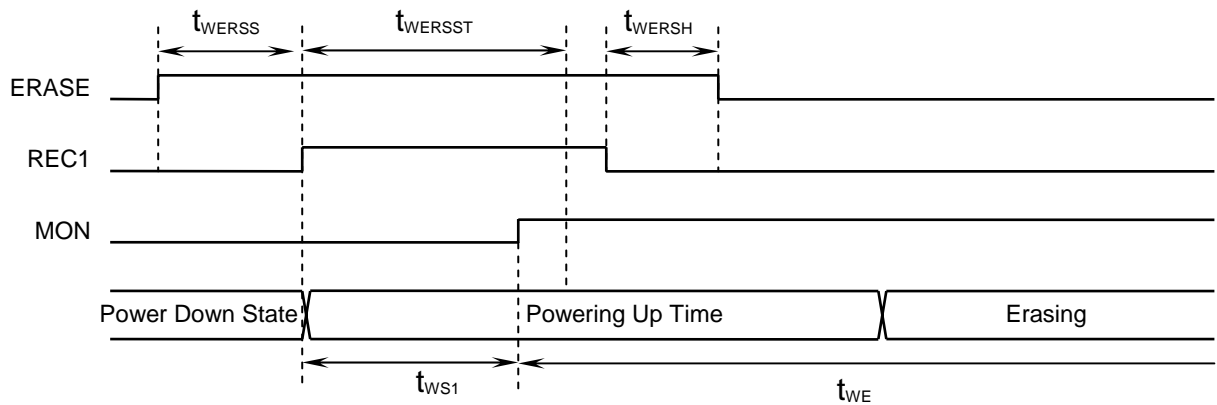

•End Erasing Phrase 1

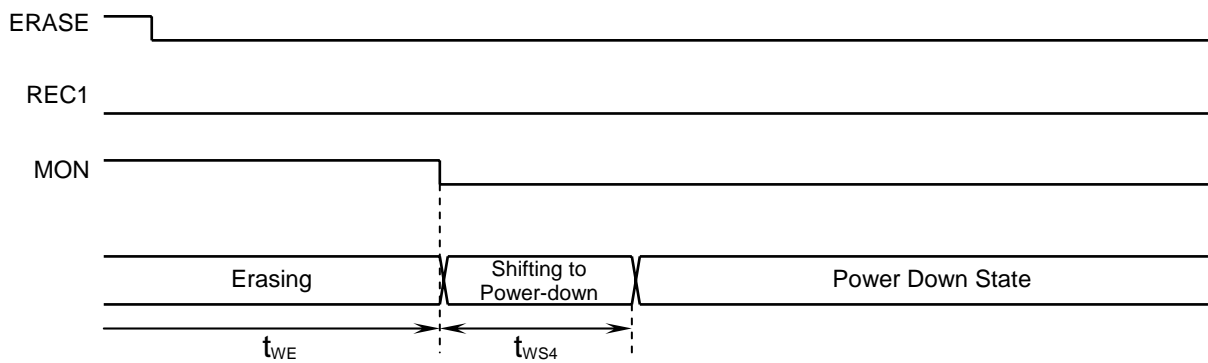

Analog Block

•Start Recording (Start recording Phrase 1)

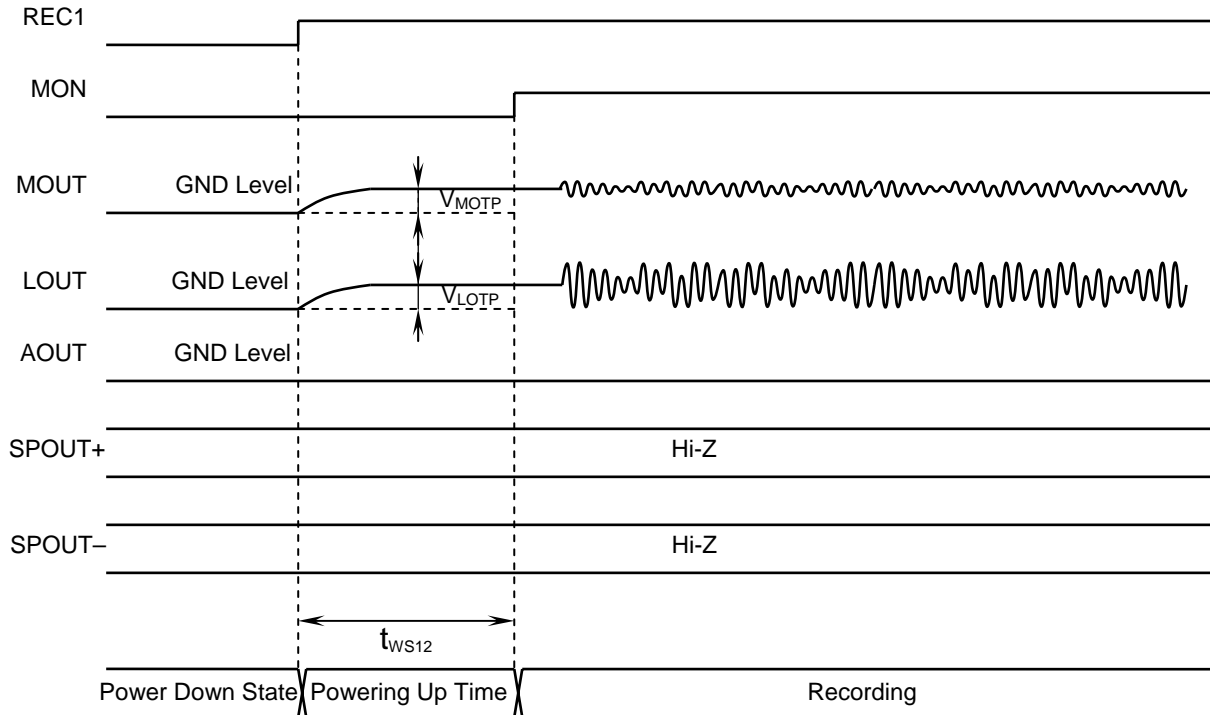

•Stop Recording (Stop recording Phrase 1)

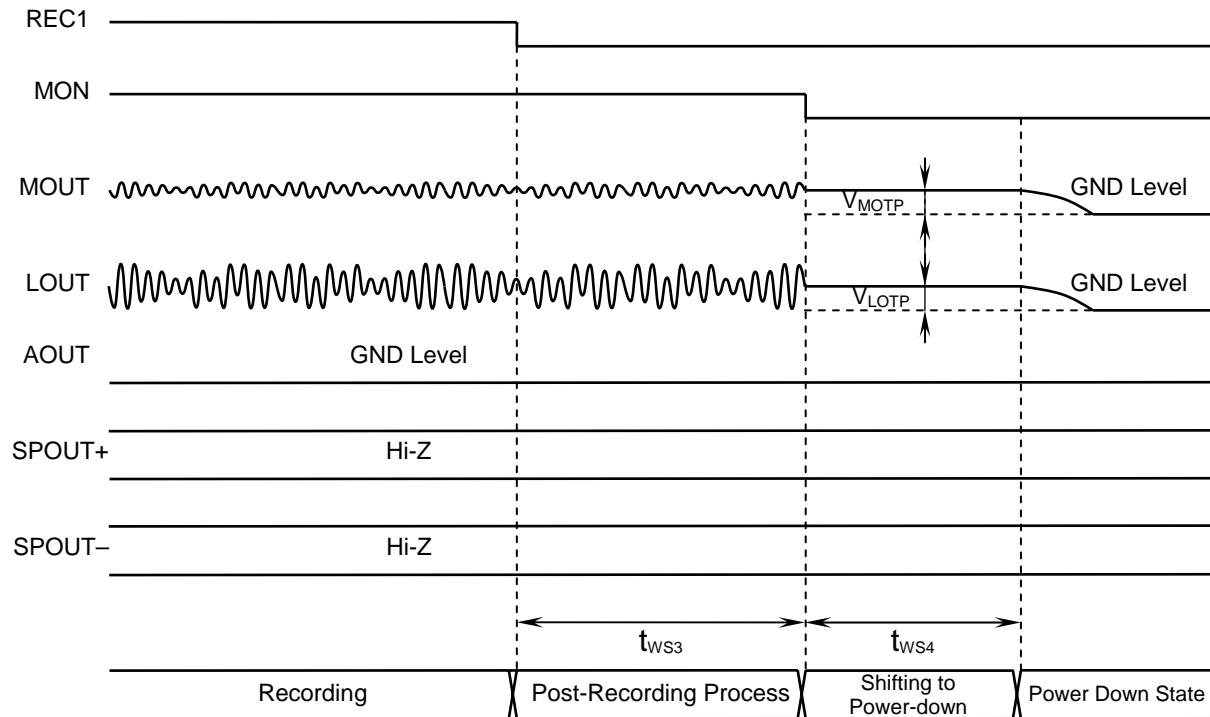

•Start Playing (Start playing Phrase 1)

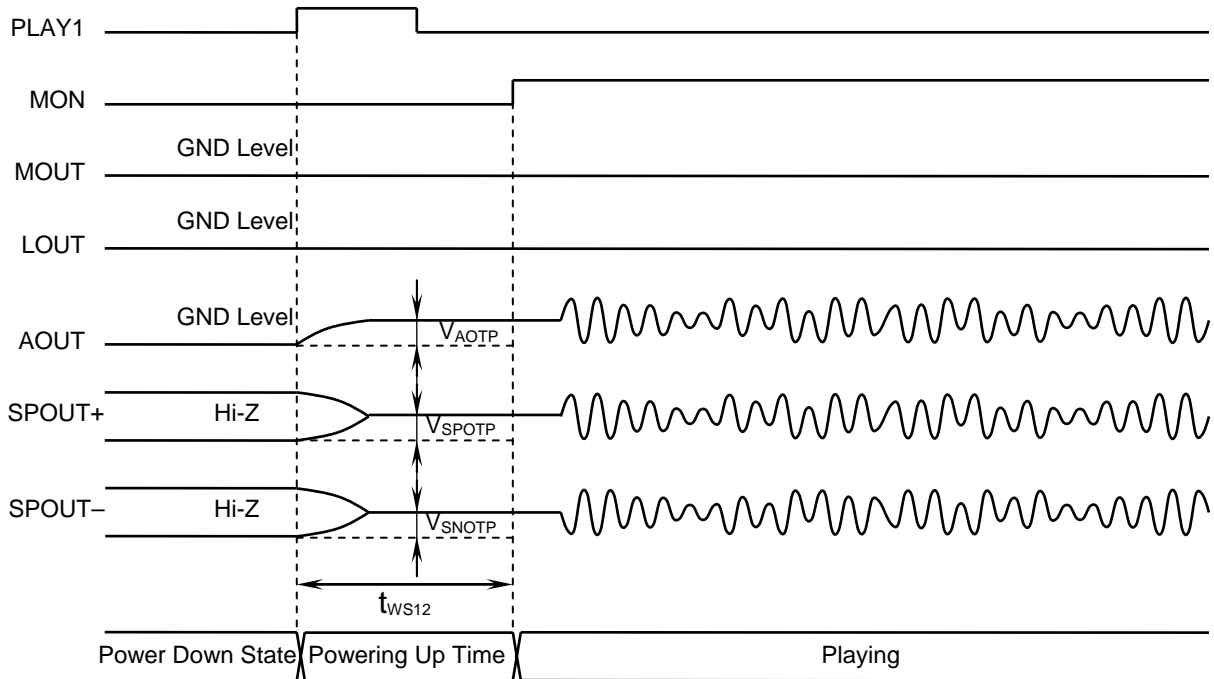

•Stop Playing (Stop playing Phrase 1)

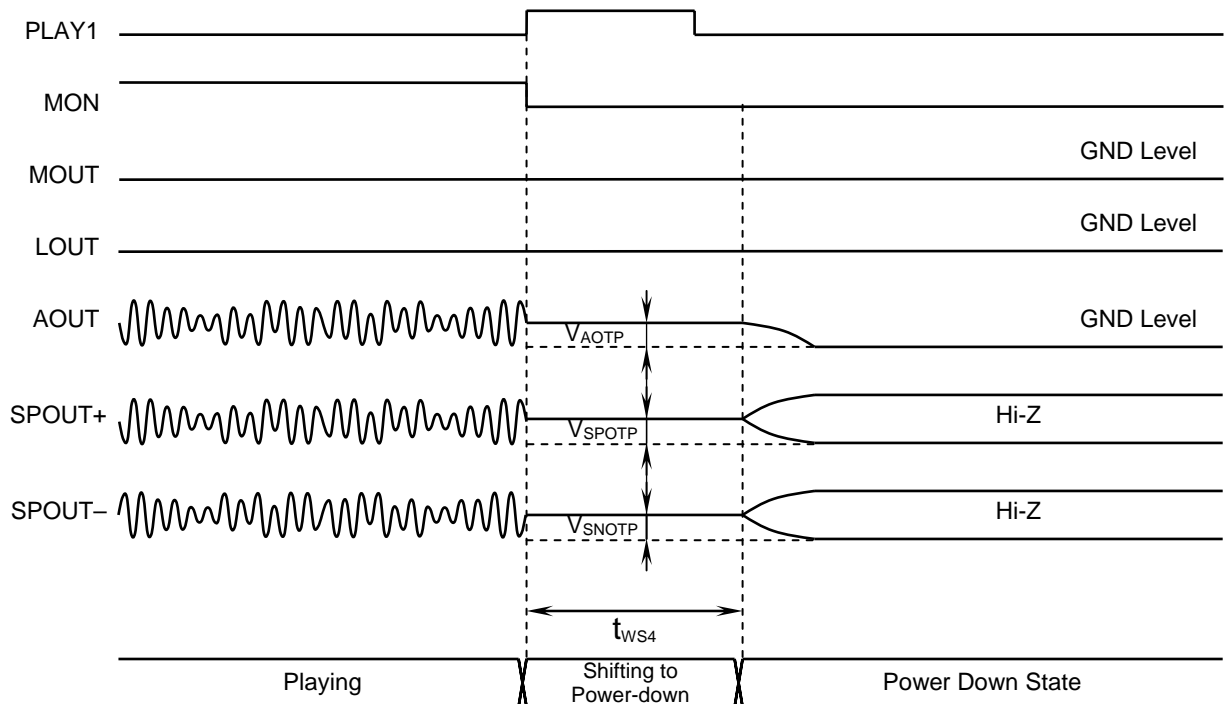

APPLICATION CIRCUIT EXAMPLE

In Single-Phrase Recording/Playback Mode, Sampling Frequency at 4 kHz; with a Dynamic Speaker

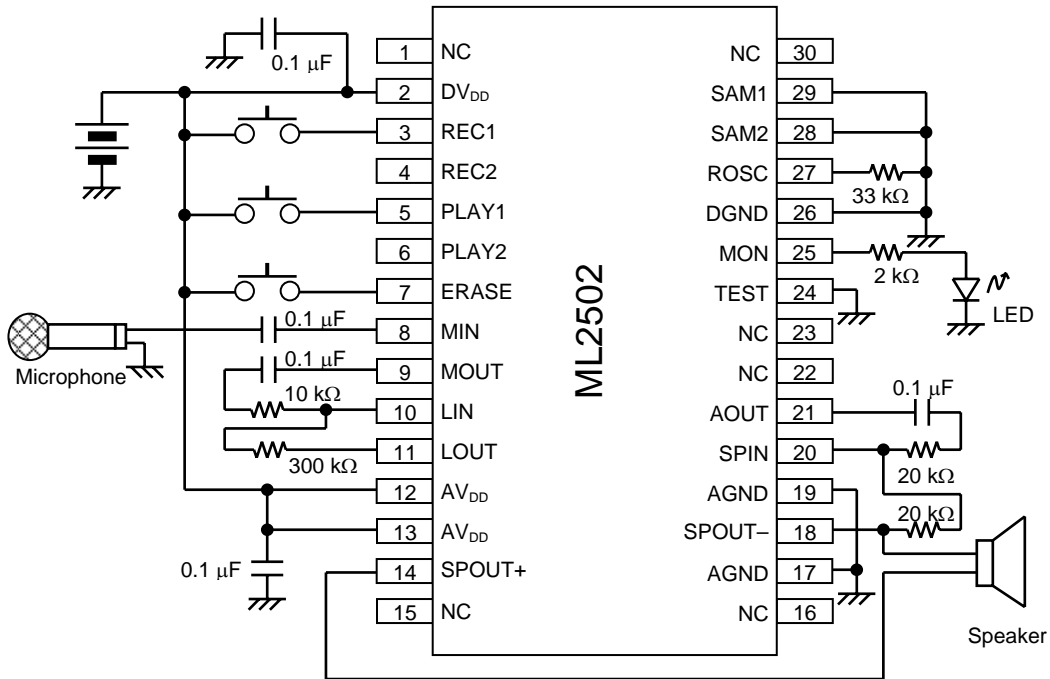

PAD LAYOUT

Die Size: 6.50 × 3.10 (mm)

Die Thickness: 350 μm ±30 μm

Pad Open Hole: 110 μm × 110 μm

Die Bottom Potential: GND

Pad location diagram(This pad layout indicates the view from the bonding pad side.)

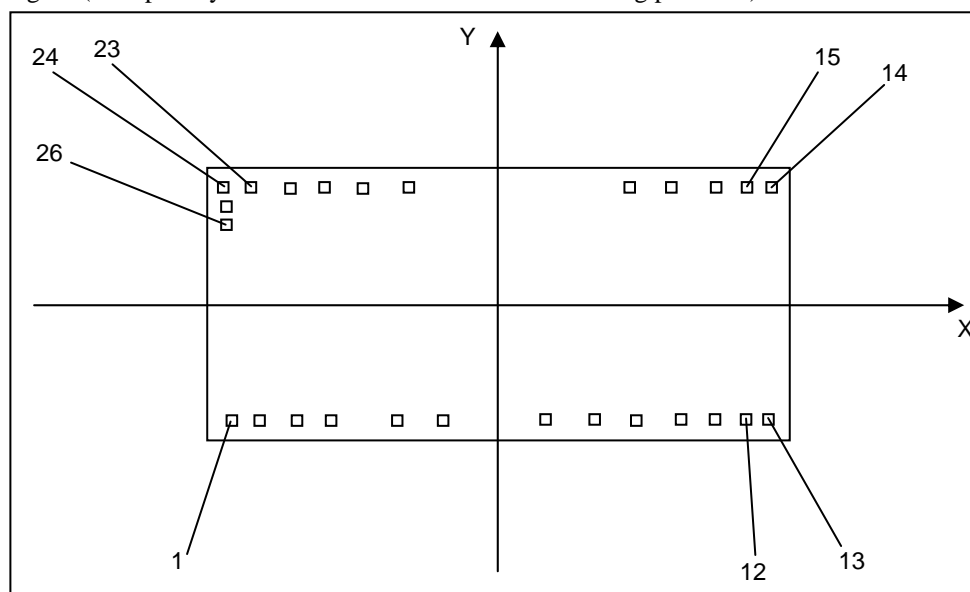

Pad Coordinates

(Die Center: X = 0 m, Y = 0 m)

Pad No.	Pad Name	X Axis [μm]	Y Axis [μm]	Pad No.	Pad Name	X Axis [μm]	Y Axis [μm]
1	DVDD	-3022	-1290	14	AGND	3105	1290
2	REC1	-2641	-1290	15	SPOUT-	2790	1290
3	REC2	-2179	-1290	16	AGND	2427	1290
4	PLAY1	-1761	-1290	17	SPIN	1851	1290
5	PLAY2	-1064	-1290	18	AOUT	1439	1290
6	ERASE	-549	-1290	19	TEST	-870	1290
7	MIN	503	-1289	20	MON	-1391	1289
8	MOUT	1037	-1289	21	DGND	-1797	1290
9	LIN	1458	-1290	22	ROSC	-2155	1289
10	LOUT	2019	-1289	23	SAM2	-2677	1290
11	AVDD	2303	-1289	24	SAM1	-3038	1290
12	AVDD	2709	-1289	Note25	TEST	3025	1074
13	SPOUT+	3040	-1289	Note26	TEST	3025	894

Note: Pad No. 25 and 26 are used for testing the LSI. No bonding is allowed to these pads.
Do not expose dies under ultra-violet ray or any light for long time

PACKAGE DIMENSIONS

(Unit: mm)

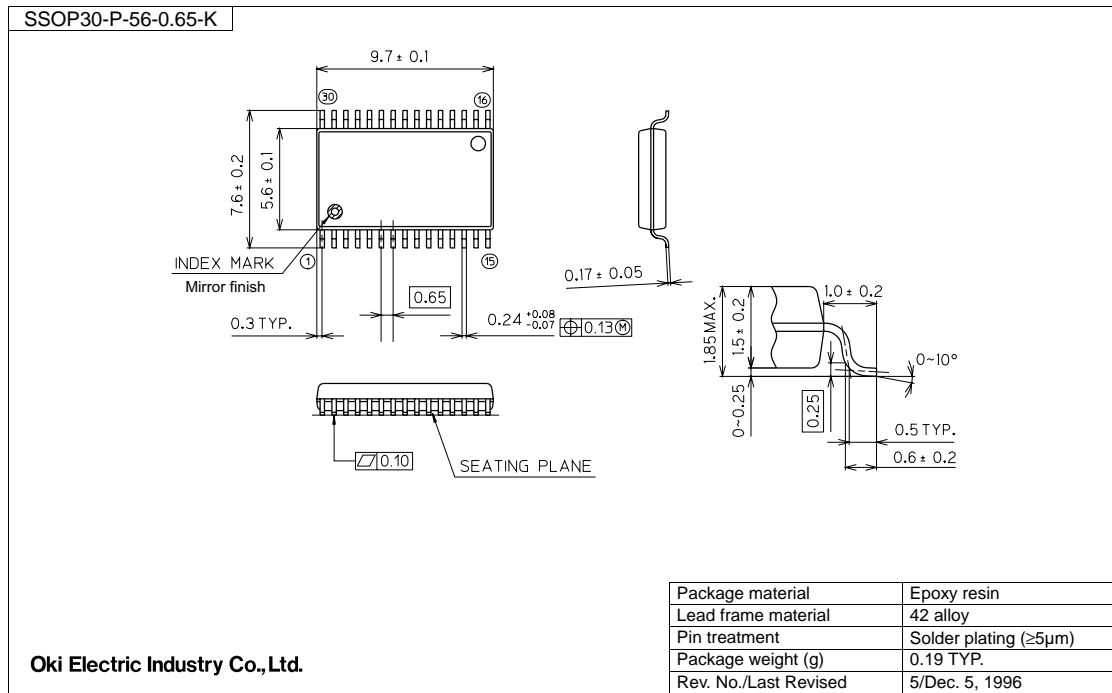

Notes for Mounting the Surface Mount Type Package

The surface mount type packages are very susceptible to heat in reflow mounting and humidity absorbed in storage. Therefore, before you perform reflow mounting, contact Oki's responsible sales person for the product name, package name, pin number, package code and desired mounting conditions (reflow method, temperature and times).

REVISION HISTORY

Document No.	Date	Page		Description
		Previous Edition	Current Edition	
FEDL2502-01	Mar. 2000	-	-	Final edition 1
FEDL2502-02	May. 2001	-	-	Final edition 2
FEDL2502-03	Aug. 9, 2004	20	20	Corrected Min. "L" Pulse Width for REC-Stop Input and Min. Pulse Width for PLAY-Stop Input.

NOTICE

1. The information contained herein can change without notice owing to product and/or technical improvements. Before using the product, please make sure that the information being referred to is up-to-date.
2. The outline of action and examples for application circuits described herein have been chosen as an explanation for the standard action and performance of the product. When planning to use the product, please ensure that the external conditions are reflected in the actual circuit, assembly, and program designs.
3. When designing your product, please use our product below the specified maximum ratings and within the specified operating ranges including, but not limited to, operating voltage, power dissipation, and operating temperature.
4. Oki assumes no responsibility or liability whatsoever for any failure or unusual or unexpected operation resulting from misuse, neglect, improper installation, repair, alteration or accident, improper handling, or unusual physical or electrical stress including, but not limited to, exposure to parameters beyond the specified maximum ratings or operation outside the specified operating range.
5. Neither indemnity against nor license of a third party's industrial and intellectual property right, etc. is granted by us in connection with the use of the product and/or the information and drawings contained herein. No responsibility is assumed by us for any infringement of a third party's right which may result from the use thereof.
6. The products listed in this document are intended for use in general electronics equipment for commercial applications (e.g., office automation, communication equipment, measurement equipment, consumer electronics, etc.). These products are not, unless specifically authorized by Oki, authorized for use in any system or application that requires special or enhanced quality and reliability characteristics nor in any system or application where the failure of such system or application may result in the loss or damage of property, or death or injury to humans. Such applications include, but are not limited to, traffic and automotive equipment, safety devices, aerospace equipment, nuclear power control, medical equipment, and life-support systems.
7. Certain products in this document may need government approval before they can be exported to particular countries. The purchaser assumes the responsibility of determining the legality of export of these products and will take appropriate and necessary steps at their own expense for these.
8. No part of the contents contained herein may be reprinted or reproduced without our prior permission.

Copyright 2004 Oki Electric Industry Co., Ltd.