

Pb Free

RoHS Compliant

Features

- Since it has a frequency dividing function, it is able to obtain a frequency division of $1/2-1/2^8$ ($1/256$)
- The symmetry of frequency divided output is within $50\pm 2\%$
- The oscillation start time has the fast starting characteristic of being 1.5msec. or less
- The pin arrangement is DIP 8PIN
- Supply voltage $V_{DD}=5.0V$

Applications

- Amusement

How to Order

KCEXO3- 20.000 C 5 1 B 00
 ① ② ③ ④ ⑤ ⑥ ⑦

- ① Type
- ② Output Frequency
- ③ Output Type (CMOS)
- ④ Supply Voltage (5.0V)
- ⑤ Frequency Tolerance
- ⑥ Symmetry/Enable Function (40/60%, Stand-by)
- ⑦ Customer Special Model Suffix (STD Specification is "00")

Specifications

Item	Symbol	Conditions	Specifications		Units
			Min.	Max.	
Output Frequency Range	F_0		11.0592	24.576	MHz
Frequency Tolerance (Overall)	F_{tol}		-100	+100	$\times 10^{-6}$
Storage Temperature Range	T_{stg}		-40	+85	$^{\circ}C$
Operating Temperature Range	T_{use}		-10	+70	$^{\circ}C$
Supply Voltage	V_{DD}		4.5	5.5	V
Current Consumption	I_{DD}		-	20	mA
Symmetry	SYM	@50% V_{DD}	40	60	%
Rise / Fall Time	Tr/Tf		-	15	nS
Output Voltage-"L"	V_{OL}		-	10% V_{DD}	V
Output Voltage-"H"	V_{OH}		90% V_{DD}	-	V
Output Load	CL		-	50	pF
Start-up Time	ST		-	1.5	mS

Note: All electrical characteristics are defined at the maximum load and operating temperature range.
 Please contact us for inquiries about operating temperature range, available frequencies and other conditions.

Dimensions

(Unit : mm)

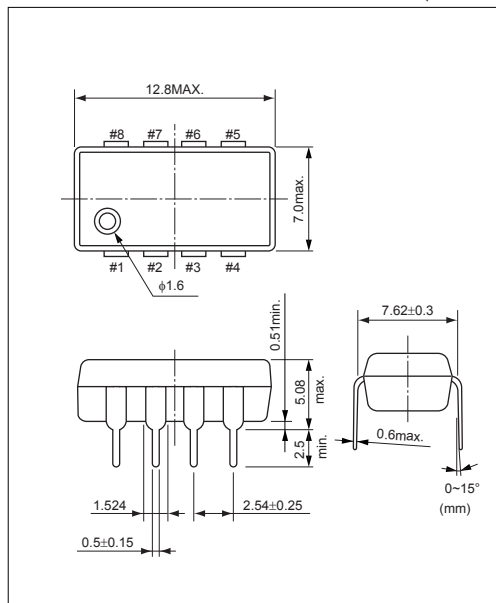

Settings of the frequency division output

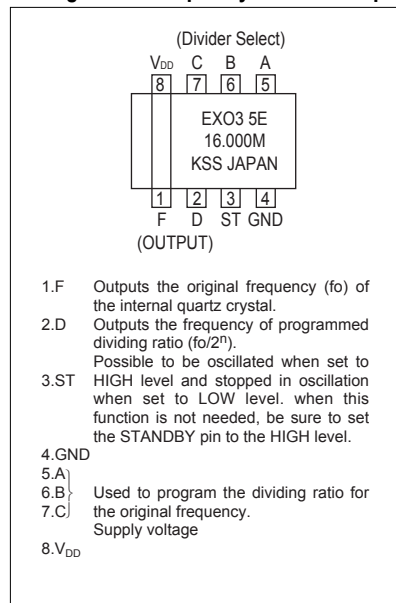

Pin connection

Input			Output	
Select	ST		F	D
C	B	A	Original Frequency	Divided Wave form
L	L	L	f_0 clock	$f_0 \cdot 1/2$ clock
L	L	H	f_0 clock	$f_0 \cdot 1/2^2$ clock
L	H	L	f_0 clock	$f_0 \cdot 1/2^3$ clock
L	H	H	f_0 clock	$f_0 \cdot 1/2^4$ clock
H	L	L	f_0 clock	$f_0 \cdot 1/2^5$ clock
H	L	H	f_0 clock	$f_0 \cdot 1/2^6$ clock
H	H	L	f_0 clock	$f_0 \cdot 1/2^7$ clock
H	H	H	f_0 clock	$f_0 \cdot 1/2^8$ clock
-	-	L	L	L